

**FORMAL ANALYSIS OF KINSHIP TERMINOLOGIES
AND ITS RELATIONSHIP TO WHAT CONSTITUTES KINSHIP
(COMPLETE TEXT)**

DWIGHT W. READ¹
UNIVERSITY OF CALIFORNIA
LOS ANGELES, CALIFORNIA 90035
DREAD@ANTHRO.UCLA

Abstract

The goal of this paper is to relate formal analysis of kinship terminologies to a better understanding of who, culturally, are defined as our kin. Part I of the paper begins with a brief discussion as to why neither of the two claims: (1) kinship terminologies primarily have to do with social categories and (2) kinship terminologies are based on classification of genealogically specified relationships traced through genitor and genetrix, is adequate as a basis for a formal analysis of a kinship terminology.

The social category argument is insufficient as it does not account for the logic uncovered through the formalism of rewrite rule analysis regarding the distribution of kin types over kin terms when kin terms are mapped onto a genealogical grid. Any formal account must be able to account at least for the results obtained through rewrite rule analysis. Though rewrite rule analysis has made the logic of kinship terminologies more evident, the second claim must also be rejected for both theoretical and empirical reasons. Empirically, ethnographic evidence does not provide a consistent view of how genitors and genetrices should be defined and even the existence of culturally recognized genitors is debatable for some groups. In addition, kinship relations for many groups are reckoned through a kind of kin term calculus independent of genealogical connections. Theoretically, rewrite rule formalism is descriptive and not explanatory of kinship terminology features. Four substantive problems with rewrite rule formalism are identified and illustrated with an example based on the concepts, Friend and Enemy. In Part II these problems are resolved when a kinship terminology is viewed from the perspective of a structured, symbolic system in which there is both a symbol calculus and a set of rules of instantiation giving the symbols empirical content.

The way in which a kinship terminology constitutes a structured symbol system is illustrated with both the American/English and the Shipibo Indian (Peru) kinship terminologies. Each of these terminologies can be generated from primitive (or atomic) symbols using certain equations that give the structure its form and where the structure is constrained to satisfy two properties hypothesized to distinguish kinship terminology structures from other symbol structures. The structural analysis predicts correctly the distribution of kin types across the kin terms when the atomic kin terms/symbols are instantiated via the primitive kin types. In addition, features of the terminologies that heretofore have been assumed to arise for reasons extrinsic to the internal logic of the terminology are shown to be a consequence of the logic of how the symbol structure is generated.

¹ Department of Anthropology

The symbol structure is linked to individuals via culturally specified instantiation of symbols. The instantiation rules can change without changing the structure. It is suggested that one's kin are determined through the symbol structure and its instantiation. A symbol structure can have more than one instantiation, thereby allowing for multiple views of who are one's kin, even if these views are mutually contradictory, as has been noted for some groups.

Probably the only way to give an account of the practical coherence of practices and works is to construct generative models which reproduce in their own terms the logic from which that coherence is generated Bourdieu (1990:92)

Introduction

Kinship is commonly viewed as based on genealogy. One's relatives, in effect, are those with whom one has a genealogical connection. This notion of kinship as being based on genealogy was made explicit by W. H. R. Rivers who defined "kinship ... as relationship which is determined, and can be described, by means of genealogies" (1924: 53). More recently, Scheffler and Lounsbury used the same idea in their comment that "[w]here the distributional criteria are genealogical and egocentric, we speak of relations of kinship" and refer to "[r]elations of genealogical connection" as "kinship proper ..." (1971: 38, 39), thereby making central, in their view, the role of genealogical connections as the basis of kinship relations. Their view echoes that of Fortes who also saw the fundamental aspect of kinship to be genealogical connections since these "are universally utilized in building up kinship relations and categories" (1969: 52). Rivers had earlier noted a similar relationship between kin terms and genealogy when he rejected the idea that kinship could be defined through kin terms since, he asserted, "terms of relationship . . . are determined by genealogical relationship..." (1924: 53). It is but a short step from this assertion about the centrality of genealogical connections to considering kin terms as a means to classify genealogically determined relationships (e.g. Scheffler 1978a: 13), hence to claims that the primary meanings of kin terms are genealogical.

If so, then the onus of what constitutes kinship lies in what is considered to be a genealogical relationship and the universality of kinship depends upon there being a constant aspect of genealogy applicable to all cultures. An obvious candidate for the latter is reproduction -- the usual basis for genealogical tracing -- but therein also lies the difficulty in trying to make genealogy the source of kinship with kin terms representing the way in which genealogical relationships are classified. According to the primary proponents of a genealogical basis of kinship, genealogy has to do with tracing of ancestry, based on the notion of genitor and genetrix, via the culturally specified persons presumed to have a congenital relationship to ego through engendering and bearing children (Scheffler and Lounsbury 1971: 37-38, 78). Further, according to Scheffler and Lounsbury, sexual intercourse must be "considered *necessary* to the processes of engendering and bearing children" (1971: 38, emphasis added) in local theories of reproduction, though sexual intercourse need not be taken as a sufficient condition for engendering and bearing children in those local theories of reproduction (1971: 30, n. 1). But then, countered Schneider, it follows that the Yapese did not have kinship in 1947-48 when he did his fieldwork among them since the Yapese informed him that "coitus had no role in conception" (1984: 73). Yet, continued Schneider, according to Scheffler and Lounsbury's definition they suddenly did have kinship twenty years later when, under the influence of American schools, they incorporated sexual intercourse in their theory of conception (1984: 119). Schneider comments: "This is truly

amazing! With one single shift in the belief system, suddenly a whole segment of a kinship system that did not exist suddenly comes into being.... Was it really not there before?" (1984: 119).

Obviously "kinship" did not arise for the Yapese only after they modified their view of conception. It might be argued, though, that at some level the Yapese must always have been aware of the relationship between coitus and pregnancy as Helmig (1998) has suggested. If so, what the Yapese meant by the irrelevance of coitus may not be with regard to a "theory" about conception, in general, but about what is needed to make a Yapese as opposed to simply a member of the species *Homo sapiens*; that is, coitus is not what makes a fetus and newborn "Yapese," but rather it is "the *doing* of the male and the *doing of the marialang* and the active intervention of the *thagith* . . . and the *performance* of the woman as a good woman..." (Schneider 1984: 74, emphasis in the original) that makes a Yapese child². Such a distinction between conception as a general process and conception as it relates to creating a member of one's group is made explicit in Jane Goodale's ethnography on the Tiwi. She reports that the Tiwi distinguish between the sexual intercourse needed for pregnancy and the dreaming needed for producing a Tiwi child. "Although the Tiwi recognize that either a husband or a lover can make a baby by having sexual intercourse with its mother, they also assert that such activity alone cannot create a *Tiwi* child. A Tiwi must be dreamed by its father, *the man to whom its mother is married*, before it can be conceived by its mother" (Goodale 1971 (1994): 138, second emphasis added). Goodale reports that the Tiwi consistently distinguish between the man who made a baby through sexual intercourse and the father of the baby being the man married to the mother. Not only is the "father" the man currently married to the mother (see also Malinowski 1913; Goodenough 1970) but the critical process for "making a Tiwi" is the father = husband's dreaming that informs a *pitapitui* (unborn individual) the identity of the woman who will give birth to the *pitapitui*. Goodale comments "A *dreaming* is the catalyst that transforms a Tiwi from the world of the unborn to that of the living. A *pitapitui* gets a *dreaming* by being found by, or finding, a father. The act of 'finding' is also called *dreaming*. . . . Once a *pitapitui* has been dreamed by its father and been told who is its mother, the women say it enters their body through their vagina and goes into the little 'egg' located in the placenta (*anera*)." (1971 (1994): 140, 141, Italics in the original)³.

Since the Tiwi unquestionably recognize the role of intercourse in pregnancy and thereby satisfy the criterion presented by Scheffler and Lounsbury for what constitutes a genitor, the fact that it is the man married to the mother that is considered to be the father and not necessarily the genitor becomes problematic for asserting a genealogical basis constructed around genitors and

² The idea that it is the work done by the male and by the female that is responsible for producing an offspring has also been noted by A. Strathern for the Kawelka in New Guinea. However the Kawelka, unlike the Yapese, consider intercourse as essential to the initial formation of the fetus (Strathern 1972: 9).

³ Scheffler (1978a: 5-13) has reviewed the assertions that various Australian groups are ignorant of physiological fathers, hence do not have a concept of genitor, and argues that closer reading of the ethnographic evidence does not support such assertions. However, what appears to be consistent is a bifurcation between pregnancy due to sexual intercourse and the entry of a "spirit-child" into the fetus; that is, a distinction between the general process of impregnation as a feature of creating a member of the species *Homo sapiens* versus becoming a member of one's group – the local equivalent of a "Tiwi child." The latter seems to be consistently viewed as the critical aspect and for this reason the "physical paternity is normally dismissed as being virtually of no practical importance" ((Strehlow 1971: 596, as quoted in (Scheffler 1978a)).

genetrixes for kinship among the Tiwi. The same problem arises with the Kawelka from the Mount Hagen area of New Guinea. Andrew Strathern observes that while semen must mix with the menstrual blood to bind it and form the fetus into which ancestral ghosts implant a soul or spirit⁴, what makes a fetus into a male as opposed to a female is the *ndating* passed from fathers to sons⁵. Unlike the status of the provider of semen as being fixed through time, the *ndating* will be traced through the mother's husband should she remarry a man from a group other than the group of her husband and "her sons are spoken of as 'being with' the *ndating* of a group other than their original one" (Strathern 1972: 12). For the Kawelka the definitional problem now arises as to whether it is the man who provides the semen or the man who provides the *ndating* that should be considered the genitor of a son. If the former, then his status as genitor based upon sexual intercourse is only partial as his "congenital relationship" to a son through transmittal of male qualities via the *ndating* apparently terminates upon remarriage of the woman who gave birth to him; if the latter, the genitor need not be a male viewed as having a role in procreation. Neither option fits well with a genealogical argument that requires a permanent, congenital relationship established through coitus and conception as the basis of kinship.

The genealogical argument could conceivably be rescued in these examples by asserting that "normally" the man married to the mother is the genitor and it is the polysemic nature of the term transliterated as "father" that is at play here, not the absence of a genealogical basis to kinship. However, the Tiwi, the Yapese and the Kawelka are not isolated "problematic cases" from one region where some reworking of the genealogical argument might be needed to maintain it as the basis for what constitutes kinship, but are only a few of many ethnographic examples that would require reworking of the genealogical argument to make it "fit" the ethnographic observations. For example, Joseph Maxwell has argued that for the Inuit of Repulse Bay "adoptive relationships are considered both 'real' and genealogical" (1996: 41), hence a strictly genealogical account based on congenital relationships would somehow have to include adopted children as part of the genealogical universe. We need to ask, then, whether the problem really lies with a genealogical definition that needs refinement, or whether the problem with fit between ethnographic reporting and the genealogical hypothesis lies with the assertion that genealogy based on genitors and genetrixes established through sexual intercourse is *the* basis of kinship.

⁴ This theory of procreation is reported to occur with the Trobrianders as well for they claim that "semen acts as a coagulant of menstrual blood, producing a clot which a spirit child (*baloma*) enters ... and which proceeds to grow" (Powell 1956: 277, quoted by Leach 1966: 48; see also Austen 1934). Yet the Trobrianders were also reported by Malinowski to assert that "The seminal fluid does not make the child. Spirits bring at night time the infant..." (Malinowski, 1932: 160). Powell considers these different viewpoints as "coexistent indigenous beliefs which though by European standards [are] mutually contradictory, as are the clan and sub-clan myths of origin, are not so in terms of Kiriwinan logic, since they relate to what Malinowski might have termed different contexts of situation..." (Powell 1956: 277). As suggested by Goodale's comments on the Tiwi, the context difference may relate to whether the context is procreation being viewed as a process shared with other animals versus procreation as a process by which a Trobriand child is created.

⁵ According to A. Strathern, the Kawelka distinguish between the role of semen in uniting with the menstrual blood to make a fetus (Strathern 1972: 9) and the "maleness" passed from father to son via the *ndating*. Males alone can possess *ndating* (Strathern 1972: 11). The distinction is remarkably parallel to the difference between a sperm as the agent which initializes fertilization of the egg and the Y-chromosome carried by the sperm that is responsible for maleness. Like the *ndating*, the Y-chromosome is responsible for maleness and is only found in males. But unlike the Y-chromosome, the *ndating* traces back from a son to male ancestors via the man currently married to his mother; i.e., it violates the basic premise of genealogy based on reproduction.

The lack of fit between ethnographic reporting and the genealogical hypothesis cannot be resolved, however, through asserting a social category view of who constitute one's kin. In Part I it is argued that the social category hypothesis does not account for the formal results that have been obtained via rewrite rule analysis, specifically the logicity of kinship terminologies as a system of symbols. This poses a quandary. The genealogical hypothesis – the basis for the rewrite rule analysis -- is not in accord with ethnographic observations and the social category argument is not in accord with the logicity of kinship terminologies demonstrated through rewrite rule analysis. To resolve this quandary it is necessary to examine in detail the assumptions underlying the formalism of rewrite rule analysis. That examination highlights the way in which the rewrite rule analysis fails to be a theoretically grounded, formal account of a kinship terminology viewed as a symbol structure. I argue that rewrite rules are descriptive and not explanatory of the structural properties of kinship terminologies viewed as a symbol system.

Yet even though the genealogical hypothesis upon which the rewrite rule analysis is based is suspect, the formal results obtained through rewrite rule analysis are valid, nonetheless, as formal descriptions of certain aspects of the structural properties of a kinship terminology. The descriptive results are features that any formal account of a kinship terminology must incorporate.

With this as a background, in Part II I discuss a different approach to a formal analysis of kinship terminology structures that is both consistent with ethnographic observation about kin term reckoning and accounts for the descriptive results obtained through rewrite rule analysis. The approach I present in Part II distinguishes the empirical structures obtained from genealogical tracing from kinship terminology properties, then brings the framework of genealogical tracing together with that of a kinship terminology structure through what I call the instantiation of kinship terminology symbols. I suggest, then, that we have two culturally defined constructs, one based on genealogical tracing and the other based on the kinship terminology viewed as a formal, culturally defined symbol structure. Instantiation of kinship terminology symbols via the fundamental elements of genealogical tracing (genealogical father, genealogical mother) leads to a genealogical perspective on who constitutes one's kin. But instantiation need not be limited to, nor be defined by, genealogical criteria, hence the formalism I introduce allows for a dynamic, changing, culturally grounded basis for who constitute one's kin that need not be subsumed under the specification of one's genealogical relations. Hence there is no need to posit either metaphorical extensions or "fictive" kin unless, for a particular group, these concepts have cultural salience.

The theory underlying Part II is tested through constructing a predicted categorization of genealogical kin type products based on the formal analysis of a kinship terminology structure. It is shown, with the American/English Kinship Terminology as an example, that the predicted mapping of kin terms onto a genealogical grid is in complete accordance with the mapping of kin terms onto the genealogical grid obtained through informant comments about the proper use of kinship terms.

Part 1: Inadequacy of Formal Accounts Based on Kinship Viewed as Social Categories or Genealogical Classes

Inadequacy of a Social Category Basis for Kinship

If the claim that kinship is determined by genealogy is suspect, then we must address directly the question: What is kinship? One alternative to a genealogical basis for kinship has

been a social definition whereby kin terms are symbols that represent social categories (Leach 1958; Needham 1962; McDougal 1964; Beattie 1964). The “social category” viewpoint has generally been used with reference to systems said to practice prescriptive alliance (Parkin 1996: 88-89)⁶, such as Australian social systems where an individual is given a social identity in a system of relationships through sections and subsections of “marriage classes.” From this viewpoint, kin terms are, seemingly, genealogical only by virtue of a happenstance concordance between genealogical reckoning and social categories, not because the categories are fundamentally about genealogy. But if kin terms were simply symbols with definitions based on already determined social categories as Leach argued in his assertion that “kinship terms are category words by which the individual is taught to recognize the significant groupings in the social structure into which he is born” (Leach 1958: 143), then there is no reason to expect that these same terms, when mapped onto a genealogical grid, should be describable in genealogical terms as was shown by Lounsbury (1965, Special Publication 62) with the Trobriand terminology (Buchler and Selby 1968: 43), among other terminologies. The congruence between social categories and genealogical representation only makes sense if the social categories are constrained in some manner by genealogical criteria. Needham identified this problem (1971: 4) in his argument for viewing kinship as systems fundamentally having to do with “allocation of rights and their transmission from one generation to the next,” (1971: 3) but provided no explanation for the fact the system so defined can also be described in genealogical terms, even though it is a telling argument against viewing kinship terms as labels for already existing social categories.

Rejecting a symbol/category notion of kinship, though, need not imply acceptance of a genealogical basis for kin terms and their interpretation. A skeptic of both positions has argued that the semantic load of kinship terms should be based instead on natural resemblance, for “in virtue of a procreative link between two persons there exists a degree of natural resemblance . . .” and “[t]he notion of natural resemblance . . . is intuitively part of the meaning of relationship terms” Hirschfeld (1986). The argument is curious as Hirschfeld accepts the formalist arguments of Lounsbury (1964; 1965), Scheffler (1972a; 1972b; 1972c; 1976; 1978a; 1978b; 1982; 1984) and Scheffler and Lounsbury (1971), as informative even though based on a presumption rejected by Hirschfeld, namely that the primary meaning of kin terms are genealogical relations. However, rewrite rule analysis is not based on the presumption that a genealogical space is simply a convenient, etic grid for analytical purposes as suggested by Hammel (1965: 4-7) and Kay (1966: 21), but rather on the claim that the genealogical grid must be part of the culture else “there could be no justification for analyzing the terms by reference to such a ‘grid’” (Scheffler and Lounsbury 1971: 70).

Hirschfeld attempts to provide linkages among kin terms, genealogical relations and natural resemblance by asserting that “[i]f certain genealogical predicates apply to two individuals, then a certain natural resemblance is also considered to exist between them. This provides a necessary association between certain calculi based on genealogical predicates and

⁶ Parkin has argued that restricting a category approach to societies based on alliance systems misjudges the universality of categories as constituting a “linguistic principle” relevant to all “human thought and speech” (1996: 105). Parkin argues for both a category approach and a genealogical approach, with the former providing the conceptual basis for kinship and the latter both a mode of analysis and a means for individuals to provide greater specificity than can often be achieved solely by reference to a category.

certain kinship terms” (1986: 237). Hirschfeld seems to be arguing that since the primary semantic meanings are (in his view) “natural resemblance” and since individuals who have a genealogical relationship are also thought to have a “natural resemblance,” then it follows that “natural resemblance” provides a linkage between terms and genealogical relations – though neither is it shown that the “natural resemblance” associated with kin terms and the “natural resemblance” associated with genealogical relations are one and the same, nor how commonality with regard to “natural resemblance” provides a basis for rewrite rules as a way to relate kin terms to genealogical linkages.

Regardless, the argument about “natural resemblance” misses the point of rewrite rule analysis. Rewrite rule analysis asserts that the primary referents of kin terms are not only genealogical, but that among the range of the (presumed) genealogical referents of kin terms, certain kin types can be identified as the primary meaning of the kin terms and the other kin types within the range of a kin term are the extended meanings of kin terms accounted for by the rewrite rules. If this claim is not valid, then demonstrating how the range of kin terms, specified via kin types, can be recovered from the supposed primary, genealogical referents of kin terms becomes formalism merely for formalism’s sake, as recognized by Scheffler and Lounsbury. The more telling aspect of Hirschfeld’s critique of what he calls the “genealogical constraint” for the meaning of kin terms lies, however, in a different area that is of direct relevance to the argument of this paper.

Inadequacy of a Genealogical Basis for Kinship

Hirschfeld observes that ethnographic evidence is hardly supportive, on the face of it, of the presumption that the meaning of kin terms is primarily genealogical and that the extension of kin terms to persons without known (or even presumed) genealogical relationship is metaphorical, or even “fictive” kinship. The *!Kung san*, among whom I did fieldwork in the early 1970’s, are a case in point. In her ethnography on the *!Kung san*, Lorna Marshall discussed the way in which two individuals who are strangers to one another establish a kinship relation. The kinship relation, though, is not established by tracing through genealogies, but through a calculation based on the use of kin terms:

“Gao [a Nyae Nyae *!Kung san*] had never been to Khadum [to the north of the Nyae Nyae region] before. The *!Kung* who lived there at once called him *ju dole* [*dole*: ‘bad’, ‘worthless,’ ‘potentially harmful’]. He was in haste to say that he had heard that the father of one of the people at Khadum had the same name as his father and that another had a brother named Gao. ‘Oh,’ said the Khadum people in effect, ‘so you are Gao’s *!gun!a* . . .’ (Marshall 1976: 242).

They determined a kinship relationship, *!gun!a*, (a person in the name giver/name receiver relationship with ego) through a kin *term* calculus that does not depend upon a genealogical space for its computation. Hirschfeld makes a similar comment about the Toba Batak who establish the proper use of kin terms through “reference to how the individuals use other kinship terms . . . not how those individuals are genealogically related” (1986: 221) and cites Sigarimbun (1975: 147) on the Karo Batak and Kelly (1974: 69) for the Etoro as other cases where a kind of kin term calculus is used to determine relationships. Similarly, Parkin (1996: 94) notes that genealogy is not the only means for determining relationships between two individuals and comments that “[t]he ethnographic literature is full of discussions of how, when two people meet for the first time, they set about determining their relationship to one another” by using kin terms and not

genealogy and cites Vatuk (1969: 96) for an example. Behrens (1984) comments for the Shipibo that "Kin terms . . . are assigned to individuals by tracing only through the terms themselves . . . two women used the kin terms they applied to a third individual in order to determine the kin relation between their offspring and that person" (p. 146).

Scheffler and Lounsbury also recognize what they call "pragmatic kin-class reckoning," but assert that it is simply reflective of the way in which only partial genealogical knowledge is needed to know the proper use of kin categories "even though the users of the system may not be accustomed to speaking or 'thinking' in the abstract of lengthy genealogical chains" (1971: 142, n. 3). Yet in the *!Kung san* example quoted above, no genealogical knowledge is invoked, only a relationship determined solely by reference to the kin categories. In a similar vein, Schneider observes that there is no reason to assume that kin type products are the only way to construct relative products⁷ (1984: 63). But Schneider does not pursue the argument further, even though it lies at the heart of the issue of what constitutes kinship and the relationship of a kinship terminology to kinship. In Part II I take up this topic directly and introduce a theory of kinship terminology structures based on relative products of kin terms, rather than the relative products of kin types. To motivate that theory, though, we need to examine the inadequacy of the formalism of rewrite rule analysis in providing an account of the formal properties of kinship terminology structures despite its descriptive successes.

Inadequacy of Rewrite Rule Analysis

Any alternative to the formalism of rewrite rule analysis must be able to achieve at least as much as has been achieved through rewrite rules, namely the rewrite rules have demonstrated that it is possible to formally account for the distribution of kin types over kin terms taking as a given the so-called focal kin types for each kin term. More generally, the rewrite rules have demonstrated logicity to kinship terminologies that any formal account must explicate. Hirschfeld, in his critique of both the genealogical constraint and social categories as the basis for the meaning of kin terms, attempted to make the rewrite rules an instance of his argument for kinship based on resemblance by asserting that resemblance provides a linkage to genealogical criteria. But Hirschfeld merely asserted the linkage and did not show how a formal account based on his theory of resemblances would, in fact, incorporate the results obtained through the formal account based on rewrite rules (Scheffler 1986: 233), hence it is inadequate as the basis for a more general formal account of the properties of kinship terminologies.

The fact that rewrite rules do demonstrate the way in which the full range of genotypes asserted to be in the class of genotypes for which the kin term is taken as a class label can be recovered from specification of the purported, primary genealogical sense of kin terms cannot be dismissed lightly. While the underlying, genealogical assumption of the rewrite rules appears to be unsatisfactory, it is possible that the problem lies in our specification of what constitutes genealogical reckoning; e.g., if one were to reckon with *pater* and *mater*, rather than *genitor* and *genetrix*, would this preserve the formalism of rewrite rules and simultaneously resolve the disquiet that the strict, genealogical claim about kinship has engendered? To put it another way,

⁷ Buchler and Selby made a similar comment about Lounsbury's success in assigning kin types to Trobriand kin terms when they observed that his success "does not assure us . . . that kinship systems are uniquely and best analyzed as genealogical codes; it is simply that we have not developed techniques as adequate for the display of other kinds of dimensions in the analysis of kinship" (1968: 20)

is the problem that arises with the rewrite rule/genealogical account primarily that a European notion of physical parentage has been mapped onto non-western “kinship systems” (Schneider, 1984: 193) or is it at a more fundamental level that has to do with what we mean by kinship in the first place, hence making the rewrite rule analysis insufficient as a formal account of a kinship terminology? To address this question we need to first consider what constitutes a formal account and secondly examine whether the rewrite rule analysis has achieved the goals of a formal account.

Formal Accounts

Lounsbury has provided a useful (though not sufficient, as will be discussed below) and succinct definition of a formal account. He defines a formal account as one in which one has identified:

“(1) a set of primitive elements, and (2) a set of rules for operating on these, such that by application of the latter to the former, the elements of a model are generated; which model in turn comes satisfactorily close to being a facsimile or exact replica of the empirical data whose interrelatedness and systematic nature we are trying to understand. A formal account is thus an apparatus for ‘predicting back’ the data at hand, thereby making them understandable, i.e., showing them to be the lawful and expectable consequences of an underlying principle or set of principles that may be presumed to be at work at their source.”

Before we can consider the extent to which a rewrite rule analysis achieves these goals of a formal analysis, we need to briefly clarify and amplify the concepts used in this definition since the way in which “model,” “empirical data,” “explanation” and “principle” are related as concepts is only implied and not made specific by Lounsbury. Once clarification is made it will become apparent that rewrite rule analysis does not achieve the goal of showing the “data at hand” to be the “lawful and expectable consequences of an underlying set of principles.”

Theory Models, Data Models, Explanation and Underlying Principles

As discussed by Read (1990), there are two models involved in a formal account, not one. If we view the primitive elements and the rules as constituting a theory (in the mathematical sense of a theory as being constituted of the primitives and rules for relating the primitives along with the properties logically derivable from these rules and primitives), then a model produced through application of the rules to a specific instance of the primitive elements can be called a model for that theory. Let us call this kind of model a *theory model* (Model_T). The validity of a Model_T lies in its construction and not by reference to empirical data; that is, we must verify that the model has been constructed in a manner consistent with the theory upon which it is based. A Model_T, however, does not predict the “data at hand,” contrary to Lounsbury’s claim, for the latter would consist of things such as the ethnographer’s field notes, tapes, videos that might have been made, and so on. Instead, at the empirical level there is yet another model, namely a model constructed as a way to represent the pattern thought to be observable in the “data at hand.” We can call this a *data model* (Model_D).

When an ethnographer presents a list of kin terms with their purported reference in terms of kin types, the ethnographer is presenting us with a data model (Model_D). In contrast to a Model_T, the validity of a Model_D is mainly an empirical, not a theoretical, matter. Validation of a Model_D involves considering both the form of a Model_D and its empirical support. Much of the

critique that Schneider has made of kinship as based on genealogy is a critique of a Model_D – the genealogical grid – constructed in accordance with genealogical criteria, i.e., a critique of the form of a Model_D for “kinship data.” Behind the choice to use a Model_D based on genealogical criteria may lie a claim that the organizing concept of kinship *is* genealogical, but this, in and of itself, does not make the model so constructed a Model_T. A genealogically based representation of kinship terms using genealogically defined kin types does not arise from application of a set of rules and their logical consequences to primitive elements, but instead represents the way the ethnographer claims the “data at hand” can be organized in a manner consistent with, and representative of, informant statements about “kinship.” Thus the ethnographer’s construction is not a model for a theory, but a model for the data at hand, hence a Model_D.

More than one Model_D can be constructed for the same data. A non-genealogical Model_D for a kinship terminology would be the kin term map introduced by Leaf (1971) as a way to display directly the relationships among kin terms without reference to a genealogical representation of the terms.⁸

With this distinction between a Model_T and a Model_D in hand we can make clearer what is involved in “explanation.” By saying a theory provides explanation for the way data are thought to be patterned as expressed in a Model_D is meant an isomorphism between a Model_T and the Model_D. When the two models are isomorphic, we can consider the theory underlying construction of the Model_T to be explanatory for the Model_D constructed as a representation of the way in which phenomena are empirically patterned. Note that this does not necessarily imply that the theory is explanatory for the phenomena in question since it is possible that the Model_D is accounted for by the theory, but the Model_D is not valid as a representation of the patterning in the phenomena in question. Scheffler and Lounsbury make this error as they seem to assume that showing isomorphism between a Model_T and a Model_D is, in and of itself, strong evidence for the theory as explanatory of the empirical reality for which the Model_D has been constructed. However, it is possible to have isomorphism between a Model_T and a Model_D, yet the Model_D is not valid. The latter is the essence of the argument advanced by Schneider against assuming kinship is universally based on a genealogical grid.

The second area that needs clarification is the implicit link made between the “rules” used in the formal account and the “principles . . . presumed to be at work at their source.” Scheffler and Lounsbury seem to be implying that the “rules” – more specifically the rewrite rules formulated to act upon the primitive elements taken to be the primary kin types – are the underlying principles that structure the kinship phenomena in question. However, there is no necessary reason to presume that any set of rules used to construct a Model_T isomorphic to a Model_D is, automatically, the set of underlying principles that, in fact, structure the phenomena in question. Nor, for example, can the rewrite rules be considered as underlying principles by virtue of being, say, universally applicable rules since the rewrite rules cannot, in general, make a claim to being universal as they may require a terminology specific form to avoid what otherwise would be errors in the predictions about the distribution of kin types across kin terms. Consider the reply Scheffler and Lounsbury made to the criticism raised by Powell (1969: 182, cited in Scheffler and Lounsbury 1971) that Lounsbury’s rewrite rules for the Trobriand terminology, specifically the “half-sibling merging rule,” would incorrectly require paternal parallel cross-cousins to be

⁸ D’Andrade (1970) has used diagrams (see his Figures 6-8) similar to kin term maps, but his diagrams conflate genealogy with terminology by using ego as a starting point and they do not include all of the kin terms.

considered as half-siblings. They comment that the “half-sibling merging rule was restricted as it was in Lounsbury (1965) because the more general and more conventional form of that rule would [incorrectly] result in the terminological identification of FBC with one or another full sibling” (1971: 49, n. 1). However, the argument becomes circular if that restricted rule, constructed to match the empirical data, is then taken as a “principle operating at the source.” Consequently, the status of the rules used in the formal account in terms of “principles operating at the source” is not determined through identifying an isomorphism between a Model_T and a Model_D, but depends upon auxiliary arguments that provide the rules with that status. The rewrite rule analysis, then, leaves unanswered the question of what constitutes the principles underlying the structural form of a kinship terminology. For this reason the rewrite rules are not explanatory in nature, but descriptive, hence part of a Model_D.

Rewrite Rules as Descriptive Formalism

The Model_D used by Scheffler and Lounsbury is a genealogically based model that posits each kin term as having, for its primary sense, some range of kin types and kin type products. Under the presumption that non-genealogical usage of kin terms is, in some sense secondary; e.g., it represents metaphorical extension of the genealogical sense of kin terms, success in terms of their stated goals would be appropriately measured via one’s ability to re-generate the range of kin types for each kin term from its focal kin types. Although Scheffler and Lounsbury are careful to distinguish between the formalism and what might be true at a cognitive level (1971: 136-150), it is evident that rewrite rules must, in some degree, reflect an emic framework if the rules are to be considered as being more than an exercise in formalism. However, success in achieving their stated goal for the formal analysis does not necessarily justify rewrite rules as, in some sense, reflecting an emic framework. So long as there are no *a priori* restrictions on the specification of the content or the form of rewrite rules, rewrite rules are what Chomsky (1963) referred to as unrestricted rewriting system. It is always possible to specify a set of rewrite rules that will precisely recover the full range of kin types for each kin term; viz., specify a rewrite rule on a term by term basis that simply says to replace the focal kin type(s) by the full range of kin types for that kin term. Neither Lounsbury nor Scheffler, the two main proponents of rewrite rules for kinship terminologies, provides any *a priori* limitation on what is an acceptable rewrite rule. Hence regardless of how kin terms are linked to sets of kin types; that is, whether kin term usage is the basis for making the linkage, or whether one simply makes arbitrary assignments unrelated to actual usage, it is possible to recover the full range of kin types from the primary kin types by *some* set of rewrite rules. While D’Andrade noted this problem with using unrestricted rewrite rules, he simply commented that “it is reassuring that most analyses [of kinship terminologies] can be accomplished with only a few rules” (1970: 112-113).

Limitations of Rewrite Rule Analysis

While the lack of an *a priori* limitation on what constitutes legitimate rewrite rules prevents the rewrite rule formalism from being, on the face of it, more than descriptive formalism, it is also apparent that there is, in fact, a logic that is at least partially captured by the rewrite rules. In their published examples of rewrite rule analyses, relatively few rewrite rules are needed and often the same rewrite rule, such as the half-sibling rule (or some variant on it), is applicable to many terminologies. Indeed, it was precisely the apparent logicity expressed through the rewrite rule analysis that led Lounsbury to challenge Leach’s assertion (1958: 143) about the illogicality

of the Trobriand kinship terminological system (Lounsbury 1965, Special Publication 62). But this still leaves open the question of what, precisely is, and is not, achieved by the rewrite rule analysis.

When examined more closely it is apparent that less is achieved than appears at first glance. More specifically, the structure of a kinship terminology viewed as a system of symbols is not accounted for. The rewrite analysis presumes the kin terms as a given and considers that the problematic area lies in the extension of terms from their primary reference via kernel kin types to their full range of kin types. Not considered in the rewrite rule analysis is the possibility that the kin terms constitute, at the level of symbols, a structured system, separate from any genealogical meaning the terms may, or may not have (Read 1984; Parkin 1996: 91). If the kin terms, taken as symbols, form a structure with its own logic – that is, a structure that can be generated via operations on certain kin terms considered to be primitive symbols – then the logic captured by the rewrite rule analysis may simply be the consequence of (1) the set of kin terms constituting a symbol structure that can be generated from a small set of primitive (or atomic) kin terms and (2) the interpretation, in the form of sets of kin types, of the primitive symbols/kin terms that serve as generating symbols for the symbol structure. In brief, in parallel to the fact that the social category argument does not account for why kin terms should have a consistent representation when considered as covering terms for genealogical relationships (hence preventing the social category argument from being a more general “theory”), the rewrite rules do not account for why kin terms should constitute a symbolic system with a structure whose form is understandable solely by reference to operations that may be done on kin terms viewed as symbols. More precisely, there are four major problems with the rewrite rule approach that prevents them from being more than a descriptive account of kinship terminology structure.

Four Problems with the Rewrite Rule Formal Account

First, the approach assumes that the primary meaning of kin terms is expressed through classes of kin type products. Second, the rewrite rules cannot account for the distribution of kin types over kin terms as the rewrite rule analysis takes as a given the primary kin types for each kin term. Third, the rewrite rules do not recognize the way in which kin terms may constitute a structured system of symbols where the structure does not depend upon the “meaning” of the kin terms, but on “rules” that relate symbols to one another. Fourth, the rewrite rules do not account for the pattern of primary kin type products for each kin term, yet that pattern has explication via the way in which the symbols form a structured system of symbols.

We can illustrate each of these four problems with an example based on the concepts, Friend and Enemy. The purpose of the example is to make clearer precisely what constitutes the shortcomings of the rewrite rule formalism as a means to account either for the structure of kinship terminologies or for what is meant by kinship. The example will be constructed in a way that parallels the basic ideas underlying rewrite rule analysis as it is applied to kinship terminologies.

We begin the example by making a distinction that parallels the distinction made between the American/English kin terms, Father and Mother, and the kin types, father and mother, with the former having cultural saliency as concepts and the later representing relations distinguished as part of genealogical tracing. We construct a parallel to kin types by introducing the idea of a “friend type.” No claim is made that a “friend type” has any status except as an analytical device allowing us to construct an example containing the equivalent of the various parts identified in the

genealogical argument for the meaning of kin terms. We construct the parallel by distinguishing between the concepts, *Friend* and *Enemy*, and the “friend types,” *friend* and *enemy*. Thus just as a person who is (culturally) identified as the “physical parent”⁹ of ego is said to have a genealogical relationship to ego described by the kin type, father, we will say that a person identified as a person who is on friendly terms with ego has the friendship relationship to ego described by the friend type, friend (that is, ego might say something like “*x* is my friend”). Further, just as one can construct kin type products of the form $xyz\dots$, where x , y and z are kin types, we will construct friend type products of the form $xyz\dots$, where x , y and z are either the friend type, friend, or the friend type, enemy. Parallel with the way in which we read kin type products, the friend type product, friend friend enemy, for example, would be read as “my friend’s friend’s enemy.” The following table (see Table 1) illustrates the parallel between kin terms and kin types and the Friend/Enemy concepts and friend types that will be used in the example.

Table 1

<i>Kin Term</i>	<i>Friend Concept</i>
Father	Friend
Mother	Enemy
etc.	
<i>Kin Types</i>	<i>Friend Types</i>
father (<i>f</i>)	friend (<i>f</i>)
mother (<i>m</i>)	enemy (<i>e</i>)
son (<i>s</i>)	
daughter (<i>d</i>)	
brother (<i>b</i>)	
sister (<i>z</i>)	

Now let us presume that we have established, via inquiry from informants, the Friend/Enemy concept that would apply to each friend type product in parallel to the way in which we might elicit from informants the kin terms that would be used with respect to each kin type product. Suppose our inquiry results in the following two sets of friend type products for the concepts, Friend and Enemy:

$$\text{Friend} = \{f, f^2, f^3, \dots; e^2, e^4, e^6, \dots; e^2f, e^2f^2, e^2f^3, \dots; fe^2, f^2e^2, f^3e^2, \dots; \dots\} = \{x_1x_2 \dots x_n\},$$

where x_i is either of the form f^j , $j = 1, 2, 3, \dots$ or of the form e^k , $k = 2, 4, 6, \dots$, and

$$\text{Enemy} = \{e, e^3, e^5, \dots; fe, fe^3, fe^5, \dots; f^2e, f^2e^3, f^2e^5, \dots; ef, e^3f, e^5f, \dots\} = \{y_1y_2 \dots y_m\},$$

where y_i is either of the form f^j , $j = 1, 2, 3, \dots$, or of the form e^k , $k = 1, 3, 5, \dots$, and at least one of the $y_i = e^k$, for some $k = 1, 3, 5, \dots$

If we use the methodology of rewrite rule analysis, we would first reduce the two sets to their primary “friend types,” namely Friend = { f } and Enemy = { e }, and then determine a series of expansion rules that would capture the full range of “friend types” for each of the two sets. This we can do via the following rewrite rules:

$$(1) \dots f \dots \rightarrow \dots ff \dots = \dots f^2 \dots$$

⁹ By “physical parent” is meant the person culturally recognized as the “physical parent” regardless of the actual genetic connection.

- (2) ...*f*... → ...*ee* ... = ...*e*² ...
- (3) ...*e*... → ...*fe* ...
- (4) ...*e*... → ...*ef* ...

For example, we could rewrite *f* as *ff* using Rule (1), then we could rewrite *ff* as *fe*² using Rule 2, hence we would include the friend type product, *fe*², in the range of friend type products for the concept, Friend. In this manner we can recover the full range of friend type products for each of the concepts, Friend and Enemy, from their focal friend types *f* and *e*, respectively; that is, we have achieved the goal of a formal analysis according to Lounsbury’s definition.

Problem 1: Primary meaning of kin terms presumed to be expressed through classes of kin type products

Success in regenerating the full range of friend type products for each of the symbols, Friend and Enemy, would, according to Scheffler and Lounsbury’s argument, constitute evidence that the primary meaning of the two concepts, Friend and Enemy, is expressed through the friend type products. However, it should be evident that interpreting Friend and Enemy in the vocabulary of friend types has no special status for the concepts Friend and Enemy even though we are able to recover the full range of friend type products from the primary friend types using our four rewrite rules. Clearly whatever is meant by the concepts Friend and Enemy is independent of the above expressions showing how friend type products would be distributed across these two concepts. Consequently, success in achieving the goal of a formal analysis does not, *per se*, establish the presumption that an interpretation of the concepts, Friend and Enemy, in the language of friend type products captures the primary meaning of these concepts.

Problem 2: Inability to predict the distribution of kin types over kin terms

Note in the example that because the rewrite rules are determined only after first having information about the friend type products corresponding to each of the concepts, Friend and Enemy, the rewrite rule analysis does not, and cannot, predict why those particular friend type products are included under each of the concepts, Friend and Enemy. From a purely formal perspective, the two sets could have had a different specification, in which case different rewrite rules would be formulated. Thus the rewrite rule is a consequence of a prior determination of the distribution of friend type products across the concepts, Friend and Enemy. Yet it is evident that the two sets are not “random” and are patterned, hence there should be an underlying logic that accounts for the pattern of friend type products included in each concept that does not require appeal to the rewrite rules; otherwise, the formal representation becomes circular. The rewrite rules do suggest, in the Friend/Enemy example, what that underlying logic might be via the form of the four rewrite rules; however, there is no assurance that such will be the case with the more complex structures of kinship terminologies.

Problem 3: Rewrite Rule Analysis Does Not Account For a Structured System of Symbols

According to the rewrite rules, apparently we have the equations, friend’s friend = friend, enemy’s enemy = friend, friend’s enemy = enemy and enemy’s friend = enemy, which suggest the corresponding statements about the concepts Friend and Enemy, viz., a Friend of a Friend is a Friend, an Enemy of an Enemy is an Enemy, a Friend of an Enemy is an Enemy and an Enemy of a Friend is an Enemy. However, the validity of the latter four statements depends upon cultural

information that informs us whether or not these statements are part of the cultural repertoire of the group in question.

In the Friend/Enemy example the rewrite rules have served a discovery function through suggesting how we might account for the distribution of the two sets of friend type products for the two concepts, Friend and Enemy. However, the rewrite rule analysis leaves that logic unformulated and untested as to its adequacy as a way to account for the distribution of the friend type products across the concepts, Friend and Enemy. To make this point clearer we need to introduce the idea of a symbol structure.

We can address the underlying logic of the Friend/Enemy contrast by shifting focus away from the interpretation of the concepts in the vocabulary of friend types back to the concepts considered as (abstract) symbols. To do so, we need a way in which we can take a pair of symbols from the set of symbols, {Friend, Enemy}¹⁰, and associate with that pair one of the two symbols, Friend or Enemy. More precisely, we need a culturally valid answer (assuming these are culturally salient concepts) to each of the following questions: (1) A Friend of a Friend is a ____? (2) An Enemy of an Enemy is a ____?, (3) An Enemy of a Friend is a ____? And (4) A Friend of an Enemy is a ____?. Let us assume that these are culturally salient questions for the group being considered, with answers:

- (1) a Friend of a Friend is a Friend
- (2) an Enemy of an Enemy is an Friend
- (3) an Enemy of a Friend is an Enemy
- (4) a Friend of an Enemy is an Enemy.

Note that neither the “meaning” the concepts might have for our informant, nor the means by which our informant decides upon the answers to the question is relevant here, only the linkage between the pair of concepts used to fill in the two blanks “a _____ of a _____” with the concept used to fill in the blank “is a _____.” More formally, the four statements serve to define a binary product over the set of symbols, {Friend, Enemy} via the predicate “of.” Let us use the symbol “o” to replace the predicate “of” and let us use the symbol “=” to replace the verb “is”. Further, for succinctness (and to emphasize that Friend and Enemy are being treated as symbols) let us use *F* in place of Friend and *E* in place of Enemy. Then we have a symbolic system consisting of (1) a set of symbols, (2) a binary product defined over all pairs of symbols taken from the set of symbols and (3) four equations or axioms that the binary product satisfies when applied to the symbols. That is we have:

- (1) a set, $S = \{F, E\}$,
- (2) a binary product, o, defined over *S* and
- (3) four axioms that determine a structure of the elements of the set *S*:
 - (a) $F \circ F = F$
 - (b) $E \circ E = F$
 - (c) $F \circ E = E$
 - (d) $E \circ F = E$.

Our symbolic system so defined has the form of an *abstract algebra*. In general, an (abstract) algebra consists of a set of symbols, *S*, and a set of rules, generally in the form of

¹⁰ Mathematical formalism uses braces “{ }” to denote a set, with the elements of the set enclosed within the braces.

equations, for combining the elements of the set S (Hermes and Markwald 1974: 65). The rules determine a particular structure for the set, S . In our Friend/Enemy example the rules are given via the binary product, o , and equations (a) – (d). Note the similarity between the concept of an abstract algebra and the “primitive elements” and “rules” in the definition of a formal account provided by Lounsbury. The formalism of abstract algebras makes the idea expressed by Lounsbury more precise.

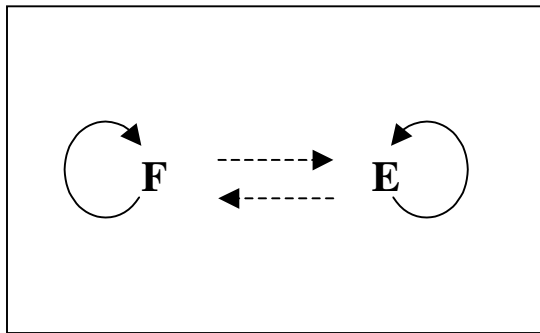

Figure 1: Structure for the concepts, Friend (F) and Enemy (E).

The structure defined is displayed in Figure 1. The structure can be “read” as follows. The symbol at the head of a solid arrow represents the result of taking the binary product of the E symbol with the symbol at the tail of the solid arrow; e.g., $E o F = E$ and so there is a solid arrow starting at F and ending at E . Similarly, the symbol at the head of a dashed arrow represents the result of taking the binary product of the F symbol with the symbol at the tail of the dashed arrow. Each arrow (solid or dashed) corresponds to one of the four equations. Observe that the structure results from information about how the concepts are related as concepts and not from the

information on how friend type products are distributed across the concepts. The structure displayed in Figure 1 cannot be determined directly from the rewrite rules as the rewrite rules only inform us about substitutions that may be made in friend type products, yet it is the fundamental structure for displaying the culturally defined relationships between the concepts, Friend and Enemy.

Problem 4: Explication of the Primary Kin Type Products for Each Kin Term

The rewrite rule analysis takes as a given the friend type products associated with each of the Friend concepts and the primary friend types for each of the concepts, Friend and Enemy. However, we can also recover the information on how the friend type products are distributed across the concepts, Friend and Enemy, from the structure displayed in Figure 1. To do so, we introduce the idea of instantiation of a symbolic element. Our familiarity with the words “Friend” and “Enemy” suggests that we interpret these concepts via the friend types, friend and enemy, respectively. Note that this depends upon a shared notion of what the concepts Friend and Enemy “mean” in terms of friend types. Otherwise, we must specify how the symbols F and E are to be mapped to specific individuals with respect to ego. Assume we agree to map the symbols F and E to the sets $\{f\}$ and $\{e\}$, respectively. We can call a mapping from (abstract) symbols to a (more) concrete form an *instantiation mapping* for the symbols.

We can now extend the above defined instantiation mapping for the symbols, F and E , to products involving the binary product, o , by means of a set product defined through (in this example) the friend type product of set elements. To do so, suppose $S = \{x_1, x_2, \dots, x_m\}$ and $T = \{y_1, y_2, \dots, y_m\}$ are two sets. Let the set product, $S \times T$, be defined by $S \times T = \{x_i y_j\}$, $1 \leq i \leq m$ and $1 \leq j \leq m$.

$\leq j \leq m$.¹¹ For example, if $S = \{x, y\}$ and $T = \{u, v\}$, then $S \times T = \{x, y\} \times \{u, v\} = \{xu, xv, yu, yv\}$. Under this definition of set products, we can “translate” a product of symbols into a set of friend type products. For the four axioms we have the correspondences:

- (a') $FF = F \rightarrow \{f\} \times \{f\} = \{f\}$, or $ff = f$ since $\{f\} \times \{f\} = \{ff\}$
- (b') $EE = E \rightarrow \{e\} \times \{e\} = \{ee\} = \{f\}$, or $ee = e$ since $\{e\} \times \{e\} = \{ee\}$
- (c') $FE = E \rightarrow \{f\} \times \{e\} = \{fe\} = \{e\}$ or $fe = e$ since $\{f\} \times \{e\} = \{fe\}$

and

- (d') $EF = E \rightarrow \{e\} \times \{f\} = \{ef\} = \{e\}$, or $ef = e$ since $\{e\} \times \{f\} = \{ef\}$

Thus our structure informs us that under this instantiation we must have the friend type product equations, $ff = f$, $ee = e$, $fe = e$ and $ef = e$, if our Friend/Enemy axioms, our instantiation and our friend type products are all to be mutually consistent. Further, we include in the set corresponding to F (alternatively, E) all those friend type products that reduce to f (alternatively, e). Note that these four equations are also the basis for the rewrite rules discussed earlier. It is evident, then, that the structure given in Figure 1, with its four axioms, accounts for the distribution of friend type products for the symbols, Friend and Enemy once we have made the above instantiation of the symbols, Friend and Enemy. In other words, the information that we are dealing with a system of symbols, hence with a logic that determines how the symbols are structured as a system of symbols, lies at a deep structural level that accounts for the primary data used in the rewrite rule analysis. Furthermore, the symbol structure also accounts for why, in this example, the rewrite rule analysis has a simple result in the form of four rules.

Symbol structure and Instantiation of Symbols

The correspondence between the structure given in Figure 1 and the distribution of the friend type products for the symbols F and E is not necessary, from a formal perspective, unless the symbol system *is* the basis upon which the two sets of friend type products are generated. Hence the correspondence between the structure given in Figure 1 and the two sets of friend type products depends upon constructing and simplifying friend type products in a manner consistent with the instantiation of the symbols F and E in the language of friend types via the axioms underlying the structure displayed in Figure 1. Thus the assertion that the distribution of friend type products across the symbols is a consequence of the logic of the symbolic system and the instantiation constitutes a theory and not a description. Further, it is the structure given in Figure 1 and not the rewrite rules that captures the “principal operating at the source.”

Observe that we can vary the instantiation of the symbols, F and E , without altering the structure displayed in Figure 1. In the context of the *!Kung san*, for example, we might attempt to instantiate F as a person with whom one has a kinship relation and E as a person who is a stranger (*ju dole*). Whether this is culturally meaningful and consistent with the four axioms is an empirical question. From a formal perspective, though, there is no greater validity in using the friend type instantiation using the friend/enemy distinction than a “kinsman/stranger” instantiation so long as the four axioms are satisfied under either instantiation. Further, there is no reason why

¹¹ In words, the product of the set S of symbols by the set T of symbols is the set (denoted by $S \times T$) that consists of all possible products of pairs of symbol products (the first symbol from the set S and the second symbol from the set T), with a symbol product denoted by $s_i t_j$, where s_i is the i th symbol in the set S and t_j is the j th symbol in the set T . This definition presumes that what the symbol products represent has already been determined. In this instance the symbols are kin types and the symbol products are already defined as kin type products.

we must insist that one, and only one, instantiation is valid within the same culture as we can easily imagine that the same structure is used differently, depending upon context. Consider two other instantiations of Figure 1 from the domain of mathematics.

Example 1: Let F be given instantiation as the number 0, let E be given instantiation as the number 1, and let \circ represent binary addition, which we will denote by $+$. Then $F \circ F = F$ becomes $0 + 0 = 0$, $E \circ E = F$ becomes $1 + 1 = 0$ (which is valid under binary addition), $F \circ E = E$ becomes $0 + 1 = 1$ and $E \circ F = E$ becomes $1 + 0 = 1$, and each of the instantiated forms of the four axioms is valid.

Example 2: Let E be instantiated with the number -1 , let F be instantiated with the number 1, and let \circ represent ordinary multiplication, \times . Then $F \circ F = F$ becomes $1 \times 1 = 1$, $E \circ E = F$ becomes $-1 \times -1 = 1$, $F \circ E = E$ becomes $1 \times -1 = -1$ and $E \circ F = E$ becomes $-1 \times 1 = -1$, and each of the instantiated forms of the four axioms is valid.

These two examples of alternative instantiations of the same structure within the domain of mathematics illustrate the way in which the same structure may have different instantiations without any one of these instantiations being deemed “primary” and the others “metaphorical.” In fact, any instantiation of F and E by use of elements from some domain and constructed in a manner consistent with the axioms provides a possible “meaning” of the symbols F and E in the context of that domain. Hence the choice for instantiating the symbols F and E via “friend types” is simply one of many instantiations that are possible and provides a meaning for F and E in the context of friend types.

Generation of Symbols

In Figure 1 we have a relative simple symbol structure in which the binary product of the primitive symbols, E and F , does not lead to any new symbols because of the nature of the four “rules” relating the symbols F and E . Lack of new symbols need not be true, in general, for symbolic systems. In the absence of the rule, $FE = E$, say, the symbolic product, FE , would need to become another symbol, say X , in the set of symbols if the symbol system is still to be closed under our binary product of symbols. We would now have, in addition to the primitive symbols, F and E , the compound symbol $X = FE$ as part of the structure.¹² The new structure is shown in Figure 2, with the arrows defined as in Figure 1. For this structure, the rewrite rules would also require that there should be prior specification of the friend type products included in the range of the symbol, X , before a complete set of rewrite rules could be formulated. Thus the rewrite rule analysis would now assume as a given that there are three symbols, F , E and X , each with its own specification of the friend type products included within its range of friend type products. That the symbol, X , can be “generated” from the symbols E and F would be absent from the rewrite rule analysis since the rewrite rule analysis presumes the symbols in the structure shown in Figure 2 are primitives. Lost in the rewrite rule analysis would be the way in which the structure shown in Figure 2 can be generated from the symbols F and E , and the three equations, $FF = F$, $EE = E$ and $EF = E$.

¹² The set S would only have to be augmented by the new symbol $FE = F \circ E$ for it to be closed under the binary product since (1) $F \circ (F \circ E) = (F \circ F) \circ E = F \circ E$, (2) $E \circ (F \circ E) = (E \circ F) \circ E = E \circ E = F$, (3) $(F \circ E) \circ E = F \circ (E \circ E) = F \circ F = F$ and (4) $(F \circ E) \circ F = F \circ (E \circ F) = F \circ E = E$.

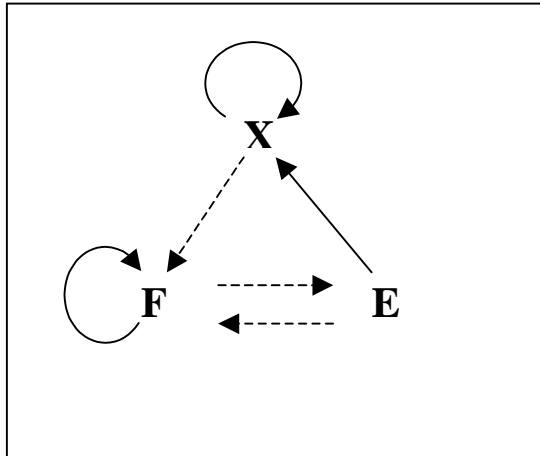

Figure 2: Structure for the concepts, F, E and $X = FE$.

Summary of Part 1 and Introduction to Part 2

We can summarize Part 1 as follows by restating the Friend/Enemy example in the language of kin terms and kin types. The rewrite rule analysis takes as its basic data model (Model_D) the set of kin terms and the range of kin type products for each of the kin terms. The goal of the rewrite analysis is to demonstrate, allegedly by constructing a Model_T, that the full range of kin type products can be recovered from the so-called focal kin type(s) for each kin term. Since there are *no a priori* constraints on what constitutes a rewrite rule, it is always possible to formulate such a set of rewrite rules, regardless of the pattern for the distribution of kin type products over the kin terms. Hence no theory is needed to construct a purported Model_T; i.e., there is, in fact, no Model_T associated with the rewrite rule analysis. Further, the set of all kin terms with their primary kin types is taken as a given, hence that set of terms and associated primary kin types has no explication within the framework of rewrite rules. Consequently, the rewrite rule analysis is descriptive, with the motivating theory being the claim that instantiation of kin terms in the vocabulary of kin type products is primary to any other instantiation. The rewrite rule analysis does not account for the distribution of primary kin types over the kin terms, and is silent on the question of whether or not the set of kin terms form a system of symbols, rather than just being a list of symbols that serve as labels for sets of kin types. Further, the fact that the rewrite rules tend to be relatively few in number and of fairly general form stems not from the genealogical assertion underlying rewrite rule analysis, but from a deeper logic that accounts for the way in which the kin terms, viewed as symbols, form a system of symbols. This deeper logic can be expressed in terms of how the kin terms, viewed as symbols, are related to one another through a “symbol product,” i.e., a kin term product, that associates with a pair of symbols one of the symbols from the set of symbols (discussed in more detail in Part 2).

Whether or not the collection of kin terms forms a system of symbols is an empirical question. If it is a system of symbols, then it should be possible to delineate how the structure can be generated from a few primary, or atomic, kin terms via a set of equations or axioms. Further, an instantiation of these atomic kin terms in the formalism of kin types can be used in conjunction with the symbol structure to generate a predicted range of kin type products for each of the kin terms. Whether or not the predicted range matches the range elicited from informants (or the range constructed by the ethnographer/analyst) requires empirical verification. Success in verification suggests that the rules used to generate the symbol structure are the likely “principles operating at the source” and the rewrite rules are an epiphenomenon of that structure and its instantiation using the vocabulary of kin types. Hence, unlike the rewrite rule analysis which is a descriptive methodology (with an underlying theory regarding kin types as the primary meaning of kin terms), the framework of viewing kin terms as a system of symbols, generateable from atomic terms, and with the range of kin types for each kin terms constructable from the structure along with the instantiation of the atomic terms in the form of kin types, constitutes a (falsifiable) theory for the structure of kinship terminologies.

Part 2: Kinship Terminologies Viewed as Symbol structures

The underlying premise for modeling the set of kin terms as a symbol structure is a “product” that associates with a pair of kin terms another kin term. The kin term product was first discussed by D. Read (1984) and is defined as follows:

Definition: Let K and L be kin terms in a given kinship terminology, \mathbf{T} . Let ego, alter₁ and alter₂ refer to three arbitrary persons each of whose cultural repertoire includes the kinship terminology, \mathbf{T} . The kin term product of K and L , denoted $K \circ L$, is a kin term, M , if any, that ego may (properly) use to refer to alter₂ when ego (properly) uses the kin term L to refer to alter₁ and alter₂ (properly) uses the kin term K to refer to alter₂.

For example, native users of the American/English kinship terminology would agree that if ego (properly) refers to alter₁ by the kin term Father and alter₁ (properly) refers to alter₂ by the kin term Mother, then ego may (properly) refer to alter₂ by the kin term, Grandmother, hence the result of computing the kin term product, Father \circ Mother, would be the kin term, Grandmother (see Figure 3).

For notational purposes, it is convenient to write kin terms with an initial capital letter to distinguish them from kin types. Kin term products will be written from right to left to represent the order in which the terms enter the product¹³ and can be read from left to right with an “of” replacing the product symbol. Thus for the kin terms, Parent and Child, in the American/English

¹³ Products are usually written left to right to match the order in which the elements enter into the product; e.g. 2×4 indicates that one begins with the number 2, then multiplies the number 2 by the number 4. Kin type products have traditionally also been written in “left to right” notation. A deliberate choice was made to write kin term products in “right to left” notation so as to permit a simple reading of kin term products that distinguishes them from kin type products. By writing kin term products from right to left, they can be read as if they are text, with the binary product, \circ , replaced by “of.” Thus $F \circ M = \text{Father } \circ \text{ Mother} = \text{Grandfather}$ would be read “Father of Mother is Grandfather” and refers to how the symbols Father and Mother are related as symbols, namely Father of Mother equals Grandfather as kin term products in the American/English terminology and not to the result of tracing kin type products in a genealogical grid. Southwold (1971) and Atkins (1974) use the same right-to-left convention for their respective notational systems. Note that kin term products are necessarily culture specific in terms of their calculation, whereas kin type products are defined in terms of a genealogical grid, hence are “culture free.”

kinship terminology, the kin term product Parent o Child can be read “Parent of Child.” The product, Parent o Child, is the kin term(s) that ego (properly) uses to refer to alter₂ when ego (properly) refers to alter₁ as Child and alter₁ (properly) refers to alter₂ as Parent, where each of ego, alter₁ and alter₂ include the American/English kinship terminology within their cultural repertoire.

The notation for kin term products contrasts with the notation for kin type products, where the kin type is usually written using an initial lower case letter and the products are usually written from left to right, with “s” used to replace the kin type product when reading a kin type product. Thus for the kin types, *f* and *d*, the kin type product, *fd*, would be read “(ego’s) father’s daughter.” Note that the result obtained from taking a kin type product, in contrast to a kin term product, is assumed to be universal and independent of any particular culture.

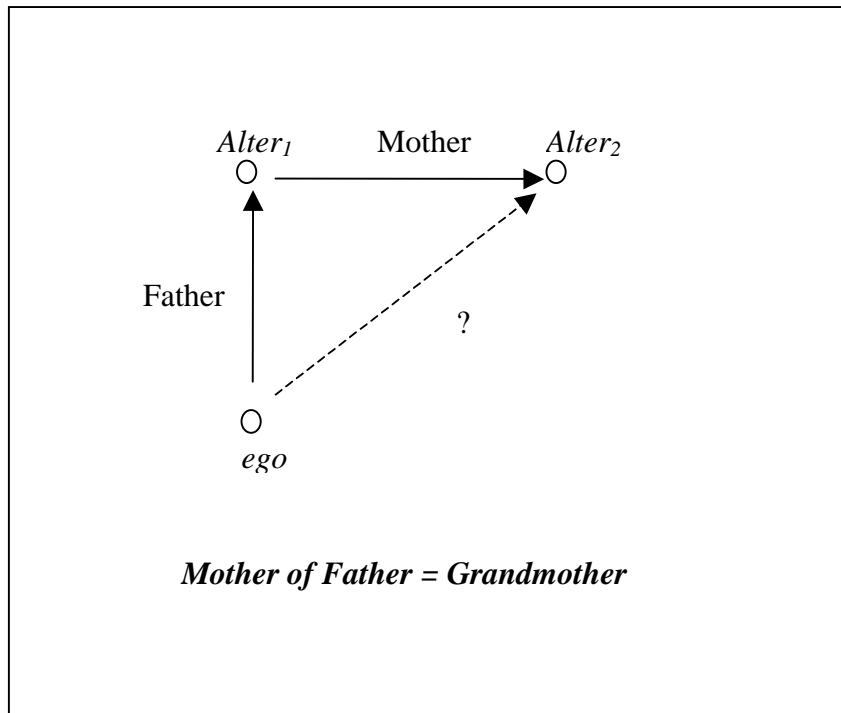

Figure 3: Graph of the kin term product, Mother of Father = Grandmother.

The kin term product is a more formal way of expressing the kind of kin term calculus that has been noted by a number of ethnographers, as discussed above. It is a way of directly linking kin terms to one another as symbols without first providing an instantiation of the symbols (e.g., via kin types) and without secondly using the instantiated form as the way to determine how one symbol is related to another symbol. Instead, kin terms are related to each other as symbols based on native knowledge about proper use of kin terms.

Whether or not the kin terms, along with the kin term product, form a structure generateable from a set of primary or atomic kin terms by use of certain equations, called structural equations, indicating which kin term products can be reduced to what kin terms is an empirical question. What must be determined for a given terminology is the set of atomic kin terms, the hypothesized structural equations and any other rules that give the structure its form. Then it must be demonstrated that the system so defined does generate a structure isomorphic to a Model_D for the kin terms expressed in the form of a kin term map that displays the way in which the kin terms are interconnected based on cultural knowledge. The beginning point for the analysis, then, is a kin term map (Model_D) in which are listed all of the kin terms and how the kin terms are interconnected when taking products with the atomic kin terms. The atomic kin terms are determined through the analysis of the kin term structure displayed in the kin term map.

Whether or not the kin terms, along with the kin term product, form a structure generateable from a set of primary or atomic kin terms by

The generation of a structure from atomic symbols and structural equations has two constraints, the *reciprocity principle* and the *focal term* property, that distinguish kinship terminology structures from other, possible, symbol structures. The first constraint derives from the notion of reciprocal kin terms; namely, if ego (properly) refers to alter by the kin term K then the reciprocal kin term would be the term L that alter (properly) uses to refer to ego¹⁴. The reciprocity of kin terms can also be extended to kin term products and to structural equations. If $K \circ L \circ \dots \circ N$ is a kin term product, then the reciprocal product would be the product written in reverse order with each term replaced by its reciprocal term. For example, the reciprocal of the product Parent \circ Cousin (= Uncle/Aunt) would be Cousin \circ Child (= Nephew/Niece) since Child is the reciprocal of Parent and the reciprocal term for Cousin is Cousin.¹⁵ The reciprocal equation for an equation would be the equation constructed by replacing each side of the equation by the reciprocal of that side of the equation. For example, if we let “0” be a symbol that represents “not a kin term” then the equation, Parent of Parent of Spouse = 0 (“Parent of Parent of Spouse is not a kin term”), would have as its reciprocal equation, Spouse of Child of Child = 0 (“Spouse of Child of Child, or Spouse of Grandchild, is not a kin term”).

We can now define the *reciprocity principle*.

Reciprocity Principle: (1) If K is an element in the symbol structure, then there is an element K^r in the symbol structure that satisfies the structural definition of a reciprocal symbol and (2) if E is a structural equation for the symbol structure then the reciprocal equation, E^r , is also a structural equation for the symbol structure.

For example, if Parent is a symbol in the symbol structure, then there must be another symbol, call it Child, where Parent and Child, as symbols, satisfy the structural definition for a pair of symbols to be reciprocal symbols. Also, if the equation Parent of Parent of Spouse = 0 is an equation used to generate the symbol structure, then the reciprocal equation derived above, namely Spouse of Child of Child = 0, must also be used in the generation of the symbol structure if the resulting structure is to satisfy the reciprocity principle. For the purpose of developing a Model_T, we require that the symbol structure we generate does satisfy the reciprocal property.

The second constraint, the focal term property, refers to the way in which a terminological structure has a term from which one may trace to all other kin terms in a kin term map representation of the kinship terminology without using reciprocal tracing. For the American/English kinship terminology this is the kin term, Self.¹⁶ By using products with the kin

¹⁴ Although the reciprocals of kin terms may be elicited from informants, from the perspective of developing a theory of kinship terminologies as symbol structures, the reciprocal of a given symbol needs to be expressed in terms of relationships among symbols and not be imposed via externally derived labeling of symbols. The formal, structural definition for the reciprocal of a symbol/term is given in Read and Behrens (1990) and Read (n.d.). It should be noted that the formalism of rewrite rules presumes that reciprocity has already been built into a Model_D for the terminology. The rewrite rule formalism considers pairs of terms to be reciprocal by virtue of the genealogical reciprocal of the kin type products included within the genealogical range for one term in the pair to be the range of kin type products for the other term in the pair.

¹⁵ If the symbols also have sex marking, the computation of reciprocals becomes more complex by virtue of the fact that a symbol may have more than one reciprocal; e.g., the kin term Father may have as its reciprocal either the kin term Son or the kin term Daughter. For a more complete discussion and formal definition of reciprocity of kin term symbol products when some of the symbols have sex markings, see Read (n.d.).

¹⁶ That Self should be considered a kin term in the American/English kinship terminology is not self-evident. Some authors such as Atkins (1974) include Self as a kin term (see Figure 2, Atkins 1974), while others do not

terms Father and Mother (or jointly, by the kin term Parent) and their reciprocal terms, Son and Daughter (or jointly, by the kin term Child), and the kin terms Husband and Wife (jointly, by the kin term Spouse), all kin terms can be reached by taking products of these kin terms with the kin term, Self, since Self acts as an identity element; that is, $\text{Kin Term} \circ \text{Self} = \text{Kin Term} = \text{Self} \circ \text{Kin Term}$, for each kin term in the AKT.¹⁷ A symbol structure will be said to satisfy the *focal term property* if there is a symbol, F , such that (1) all kin term products with the atomic kin terms originate at the kin term F and (2) every other symbol can be obtained by taking a suitable product of the atomic symbols with the symbol, F . We require that symbol structure we are generating satisfy the focal term property.

Now consider how the American/English terminology (see Figure 4 for a kin term map representation of the American/English kinship terminology) can be represented as a symbol structure generated from atomic elements through use of certain structural equations, with the symbol structure satisfying the reciprocity principle and containing a focal term. For the American/English terminology¹⁸, the atomic kin terms are determined to be (see Read 1984; Read and Behrens 1990):

Atomic Terms: Self, Parent and Spouse.

The term, Self, is an identity term, which also makes it a focal term:

Identity Term: Self.

It is so identified by virtue of the equations the term, Self, must satisfy to be an identity element, namely $\text{Self} \circ \text{Self} = \text{Self}$, $\text{Self} \circ \text{Kin Term} = \text{Kin Term} \circ \text{Self} = \text{Kin Term}$. In order to satisfy the reciprocity principle, a term, call it Child, must be included, along with the structural equation that determines Child to be the reciprocal of the term Parent (see Read n.d. for a detailed discussion of reciprocal structural equations):

Reciprocal Term: Child

include Self as a kin term. It is difficult to resolve the dispute on the basis of usage and/or linguistic form. The linguistic form, myself, is consistent with phrases such as “my parent” or “my child” and “self” is how an English speaking ego would label an alter who also happens to be ego. But the ultimate test is its position as a symbol within a symbol structure. The logic of the structural analysis of the American/English terminology makes it evident that Self must at least be a covert, if not an overt, kin term. One of its key properties is that it acts as an identity element for kin term products.

It should be noted, though, that the argument for inclusion of Self as a kin term in the American/English terminology does not imply that all terminologies have a term that is the structural equivalent of Self. The Trobriand terminology has no structural position isomorphic to the Self of the American/English terminology as it neither has a term that acts as an identity element under kin term products nor is such a symbol needed for the logical completeness of the Trobriand Kinship Terminology symbol structure.

¹⁷ More precisely, $\text{Kinterm} \circ \text{Self} = \text{Self}$, for if ego refers to alter₁ by Self and alter₁ refers to alter₂ by Kinterm, then alter₁ is actually ego and so ego refers to alter₂ by Kinterm. A similar argument justifies the equation $\text{Self} \circ \text{Kinterm} = \text{Kinterm}$.

¹⁸ Space does not permit presenting the analysis used to justify the kin term structures discussed here. The interested reader should consult Read (1984) for an algebraic analysis of the American Kinship Terminology. The algebraic analysis has been implemented as a computer software program, Kinship Analysis Expert System KAES) and the program is described in Read and Behrens (1990) and Read (n.d.), along with the results derived for the American/English, the Shipibo and the Trobriand terminologies. The KAES program may be obtained from the author at dread@anthro.ucla.edu.

Reciprocal Structural Equation: Parent o Child = Self¹⁹ (in the consanguineal space). (1)
 The term, Spouse, is self-reciprocal as determined by:

$$\text{Structural Equation: Spouse of Spouse} = \text{Self.} \quad (2)$$

Both of these equations satisfy the reciprocity principle, as each is a self-reciprocal equation.

Additional structural equations that construct the structural relationships among these elements are shown (Read 1984, n.d.; Read and Behrens 1990) to be:

Structural Equations:

$$\text{Spouse of Parent} = \text{Parent} \quad (3)$$

$$\text{Parent of Parent of Spouse} = 0 \quad (4)$$

(i.e., Parent of Parent-in-law is not a kin term)

$$\text{Parent of Spouse of Child} = 0 \quad (5)$$

(i.e., Parent of Child-in-law is not a kin term)

and

$$\text{Spouse of Child of Parent} = \text{Child of Parent of Spouse} \quad (6)$$

(i.e., Spouse of Sibling = Sibling of Spouse = Sibling-in-law).

In order to satisfy the reciprocal principle, the reciprocal equation for each of Equations (3) and (4) must be included (Equations (5) and (6) are self-reciprocal equations):

Reciprocal Equations:

$$\text{Child of Spouse} = \text{Child} \quad (3')$$

(the reciprocal equation for Equation (3)) and

$$\text{Spouse of Child of Child} = 0 \quad (4')$$

(the reciprocal equation for Equation (4)).

¹⁹ In general, for users of the AKT, if ego refers to alter₁ as Child and alter₁ refers to alter₂ as Parent, then ego could refer to alter₂ as Self or as Spouse since alter₂ could either be ego or ego's spouse. The analysis of the American/English kinship terminology demonstrates that the complete structure is generated first from a consanguineal structure based on the atomic terms, Self and Parent (and reciprocally, Child) and the equation Parent of Child = Self, and secondly by expanding this structure through addition of the Spouse symbol. The equation, Parent of Child = Spouse, does not apply to the consanguineal structure since the symbol, Spouse, is not included in the consanguineal structure. For the consanguineal structure the proper equation is Child of Parent = Self. Only after the consanguineal structure is generated is the structure expanded by adding the Spouse symbol along with the structural equations involving the Spouse symbol.

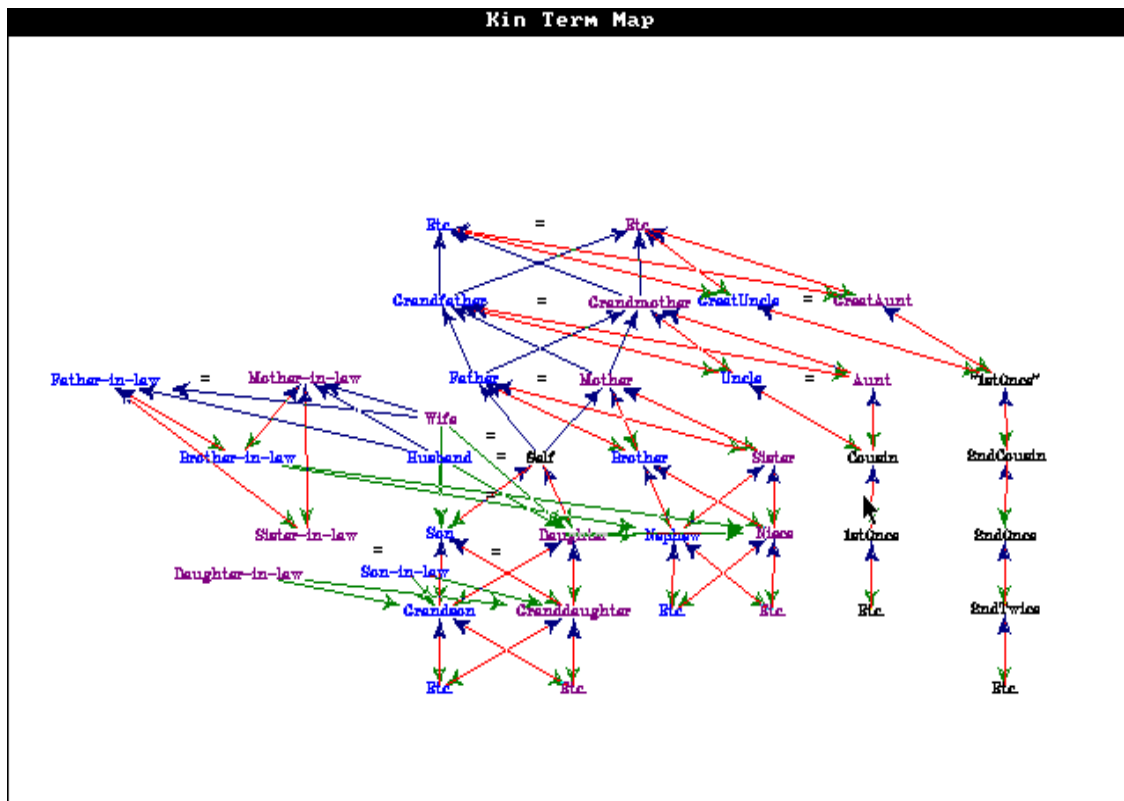

Figure 4: Kin term map for the American Kinship Terminology. Upward arrows represent the result of taking kin term products with the kin term, Parent. Downward arrows represent the result of taking kin term products with the kin term, Child. The “=” sign represents the result of taking kin term products with the kin term, Spouse. The nodes labeled with Etc. indicate that the map continues using the same pattern as displayed in the immediately preceding nodes.

Analysis of the terminology determines that it first consists of a “consanguineal” structure based on the atomic terms Self and Parent (with its reciprocal, Child) and Equations (1) and (2) (see Figure 5). The distinct symbols for the consanguineal structure are of the form Self, Parent^{*i*}, Child^{*i*} or Child^{*i*}Parent^{*j*}, where by Parent^{*i*} is meant *i* repetitions of the term Parent, and similarly for the other expressions²⁰. Each of these symbol expressions can be linked to a (consanguineal)

²⁰ Southwold (1971) almost identifies this symbol structure in his consideration of what constitutes kinship. He identifies a parentage relation, *P*, along with its converse, *P**, and considers parentation to be the class of all relative products of *P* and *P**. To define kinship, he considers a subclass of parentation, *Q*, which excludes all relative products “in which a *P* precedes a *P**” (1971: 45). The equation, Parent of Child = Self, in fact, establishes his condition for the class *Q* since the equation Parent of Child = Self, restated in his symbolism, leads to $PP^* = I$, where *I* is an identity element, hence any relative product in which a *P* precedes a *P** can have the subproduct, PP^* , replaced by an identity element, *I*, and since $IX = X = XI$ for any relative product, *X*, the symbol *I* may also be deleted without changing the relative product. Thus the equation Parent of Child = Self implies that the original relative product can be reduced to an equivalent relative product in which there are no subproducts of the form PP^* . He then considers kinship to be the situation “Where an array of social relationships is mapped onto an array of *Q* relations” (1971: 46). With the exception of the Self symbol, his class *Q* is precisely the consanguineal structure defined here,

but with the *presumption* that the symbols P and P^* are to be given instantiation as social parent and the reciprocal of social parent, respectively.

Atkins (1974) uses the term, parenthood, rather than parentation, for the basic relation from which relative products are constructed, but otherwise his system of relative products (based symbols glossed as “is a parent of” and “is a child of”) is essentially identical to that of Southwold. Just as Southwold assumes that no P is preceded by a P^* , Atkins asserts that the ‘is a parent of’ relation cannot be preceded by a ‘is a child of’ relation. They differ, though, in their goals.

Whereas Southwold uses the formalism to provide a definition of kinship, Atkins links his formalism directly to genealogical tracing through requiring the parenthood relation to be a “dyadic, irreflexive, antisymmetric, nontransitive, and many-many relation for which the informal gloss ‘is a parent of’ is anthropologically acceptable ... [and with converse] ‘is a child of’” (1974:3). Atkins uses his formalism to define and compare what he calls the fundamental consanguineal numbers defined through a diagram identical in form to the symbolic structure shown in Figure 5 (see his Figure 2 in which the nodes are labeled with kin terms from the AKT).

Though ostensibly based on genealogical tracing, Atkins eliminates the complexities that would arise with unconstrained genealogical tracing by requiring that in any tracing from person X to person Y , when an ancestor, A , for both ego and alter is used as the reference point for (consanguineally) linking ego and alter, then the single ascending line from ego to A (based on “is a parent of”) excludes any person in the single (genealogical) descending line from A to alter (based on “is a child of”). Thus the reference ancestor, A , is also the closest common ancestor for ego and alter. Atkins must introduce this artificial constraint on genealogical tracing in order to produce a structure in which (1) only (genealogical) consanguineal relations are included and (2) the number of steps from ego to the nearest common ancestor of ego and alter is also the number of steps from ego to the reference ancestor A that links ego and alter, and similarly for alter.

Without these restrictions on genealogical tracing the “fundamental consanguineal numbers” discussed by Atkins could not be unambiguously defined. His assumptions also imply that the ancestral, reference person A must have two offspring that define two distinct nodes even though the offspring are siblings and otherwise siblings are represented by a single node. It is this last property that introduces collateral lines. In effect, Atkins has simply added enough constraints on genealogical tracing so that under his constrained genealogical tracing the distinct nodes are precisely the nodes that also have a unique kin term in the AKT. But in so doing Atkins confounds actual persons (“let now an *Egocentric geneclass* be defined as any set or class of all persons who stand in a given (specified) relation to a person called Ego” (1974:5), italics in the original, emphatic underlining added), genealogical tracing based on idealized persons (e.g., the reference ancestor A must have two offspring that define exactly two distinct nodes), and kinship terms (mapping of kin terms to nodes in his Figure 2).

Yet all of his results about consanguineal numbers only require the structural form (excluding directionality of arrows) of his Figure 2 for their definition. Since that structural form can be produced directly via products of the kin terms, Parent, Child and Self, subject to the structural equation, Parent of Child = Self (an equation valid in the consanguineal structure to which Atkins restricts himself), all of his arguments about consanguineal numbers can be derived *directly* from the symbolic structure defined by the above symbols and structural equation (compare Figure 5 with his Figure 2), and *derivatively* as genealogical properties by virtue of the instantiation of the symbols Parent, Child and Self via ‘is a parent of’, ‘is a child of’ and ‘ego’, respectively (see discussion in the body of the text for more details).

Atkins recognized that his consanguineal numbers are not about genealogy, per se, but are about some of the features of a structure which has genealogical interpretation for he begins his analysis by refusing to assign meaning to “parent” in his symbolic representation of genealogical tracing that uses “is parent of” and ends the analysis by commenting that “the prospect of anthropological agreement on the metaphysics of parental essences is remote” (1974:29). Since the consanguineal numbers are not properties of genealogical tracing, per se, their cultural salience depends upon the structure used to define them also having cultural salience. Thus, even something like nearness of kin refers not to a universal, genealogical measure, but to the way relations are structured through a terminology. As noted by Godelier et al., “[t]he kinship terminology of English ... involv[es] a quite different logic of ‘near’ and ‘far’ relatives” based on lineal and collateral relatives, whereas a Dravidian terminology “sorts kin into two grades of nearness: near (parallel) and far (cross)” (1998: 8).

kin term; e.g., Parent² would correspond to the kin term, Grandparent. To this consanguineal structure is added the atomic term, Spouse, along with equations (3) - (6) which express the consequence of taking products of the symbols in the consanguineal structure by the term, Spouse.

Some kin terms in the AKT are bifurcated into sex marked kin terms. The rule for so doing is the:

Sex Marking Rule: If (1) K is a kin term and Spouse of K is a kin term, or if (2) K is the reciprocal of a kin term, T , where Spouse of T is a kin term, then K is bifurcated into a female marked and a male marked kin term.

For example, Spouse of Parent is the kin term Parent, so the kin term Parent is bifurcated into two sex marked kin terms, namely Mother and Father. Since Child is the reciprocal of Parent and Spouse of Parent is a kin term, then Child is bifurcated into two sex marked kin terms, namely Son and Daughter. However, Spouse of Cousin is not a kin term, hence Cousin is not bifurcated into sex marked kin terms.

Finally, we account for the labeling of the Cousin terms in the American/English terminology by the:

Cousin Rule: Cousin terms are labeled in such a manner that a maximum number of Cousin terms are distinguished consistent with the requirement that all Cousin terms be self-reciprocal.

The rule needs elaboration. The rule requires that all Cousin structural position terms (that is, products of the form $\text{Child}^m\text{Parent}^n$, where $m, n \geq 2$) be self-reciprocal. Self-reciprocity is an extension of the fact that the Cousin terms, First Cousin, Second Cousin, etc., all of which are of the form $\text{Child}^m\text{Parent}^m$, $m \geq 2$, (e.g., First Cousin = $\text{Child}^2\text{Parent}^2 = \text{Child} \circ \text{Child} \circ \text{Parent} \circ \text{Parent} = \text{Grandchild} \circ \text{Grandparent}$, or in words, First Cousin is Grandchild of Grandparent) must be self-reciprocal as a consequence of their structural form (that is, the reciprocal of the product $\text{Child}^m\text{Parent}^m$ is also $\text{Child}^m\text{Parent}^m$ since both exponents are the same number). When the exponents are not the same, the “ i th Cousin j times removed” nomenclature preserves “distance” (the smaller of the exponents, m and n , minus 1 makes the term an i th Cousin term) and makes the terms self-reciprocal (the absolute value of $m - n$, denoted in mathematical notation by $|m - n|$, is the “ j ” in “ j times removed” part of the term). For example, the kin term 3rd Cousin twice removed = $\text{Child}^5\text{Parent}^3 = \text{Child}^3\text{Parent}^5$ since $3 = (\text{smaller of } 4, 5) - 1$ and $2 = 5 - 3$ for each of the products, $\text{Child}^5\text{Parent}^3$ and $\text{Child}^3\text{Parent}^5$. The nomenclature also maximizes the number of distinct Cousin terms since each product of the form $\text{Child}^m\text{Parent}^n$, $m < n$, is given its own label²¹, namely “ i th Cousin j times removed,” where $i = m - 1$ and $j = |m - n|$.

²¹ The more recent collapsing of all Cousin terms by many Americans to the single term, Cousin, is also consistent with self-reciprocity, but minimizes the number of distinct cousin terms.

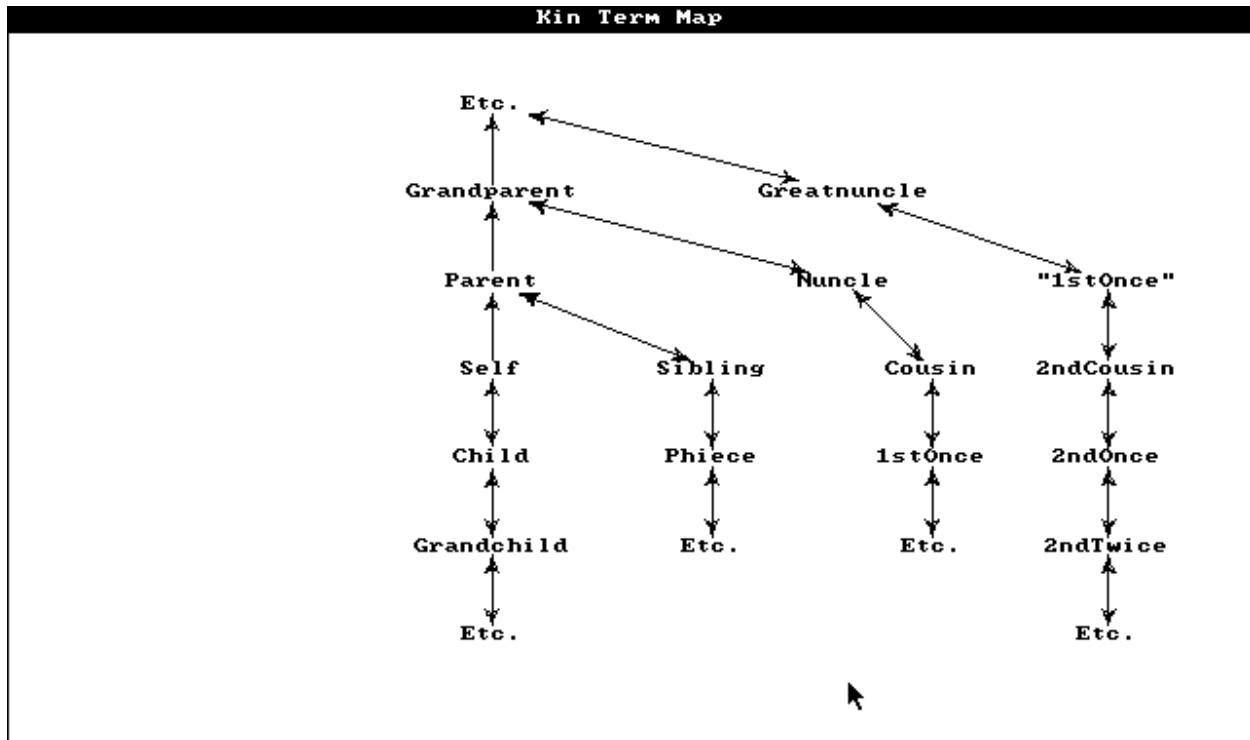

Figure 5: Kin term map for the non-sex marked, consanguineal kin terms for the AKT. Pseudo kin terms, Nuncle and Phiece, have been introduced for the kin term pairs Uncle/Aunt and Nephew/Niece. The terms, 1stOnce and "1stOnce" are the same kin term, 1st Cousin Once Removed that occurs at two nodes. The Etc. indicates that there are additional kin terms using the same structural arrangement as the term preceding the Etc. term.

The symbolic system so defined (see Figure 6) is a Model_T as it has been based on a theory of kinship terminologies as having a symbol structure that can be generated from atomic symbols along with appropriate structural equations and where the structure so generated must also satisfy both the reciprocal principle and the focal term property. The Model_T has a structure isomorphic to the kin term map (Model_D) for the American/English kinship terminology shown in Figure 4 (Read and Behrens 1990; Read n.d.), hence serves as an explanation for that Model_D. It now remains to show how the distribution of kin types for the kin terms in the American/English

terminology can be recovered from the symbolic system and its structure.

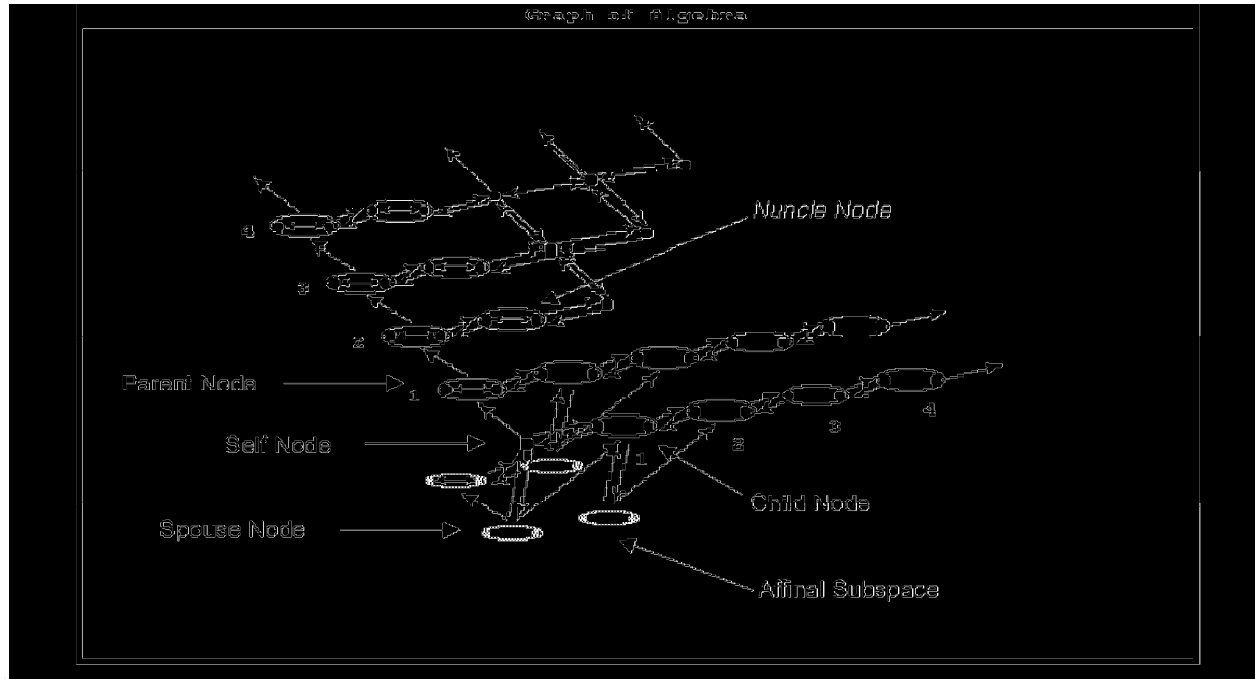

Figure 6: Graph of the algebraic structure isomorphic to the kin term map for the AKT. The nodes for the generating symbols, Self, Parent, Child and Spouse are indicated with arrows. The latter three nodes are bifurcated into two nodes due to the rule for sex marking of symbols. The gray nodes in the bottom part of the graph form the affinal subspace and are precisely the nodes marked with an “-in-law” suffix when the algebraic structure is mapped to the kin term map.

To do so, let us make the following instantiation of the atomic kin terms with respect to kin types:

$$\text{Self} \rightarrow \{ego\}$$

$$\text{Parent} \rightarrow \{f, m\}$$

$$\text{Child} \rightarrow \{s, d\}.$$

For the sex-marked forms of the atomic terms we make the following instantiations:

$$\text{Father} \rightarrow \{f\},$$

$$\text{Mother} \rightarrow \{m\},$$

$$\text{Son} \rightarrow \{s\},$$

and

$$\text{Daughter} \rightarrow \{d\}.$$

In addition, we introduce the following two kin type product equations²²:

²² The two kin type definitions are not needed for the construction of the range of kin type products for each kin term but are introduced to keep the construction consistent with the usual manner in which kin types are presented, namely that b (brother) and z (sister) are considered primary kin types.

$$b = fs = ms$$

$$z = fd = md.$$

We construct the range of kin type products for each kin term by use of the set product introduced above in the example involving the concepts, Friend and Enemy. Thus, for the kin terms Parent, Grandmother and Cousin we have:

- (1) Parent $\rightarrow \{m, f\}$,
 (2) Grandmother = Mother o Parent
 $\rightarrow \{m, f\} \times \{m\} = \{mm, fm\}$

(with the order of the set product reversed from the order of the kin term product for Grandmother since kin type products are written from left to right and kin term products are written from right to left) and

- (3) Cousin = Child o Child o Parent o Parent
 $\rightarrow \{m, f\} \times \{m, f\} \times \{s, d\} \times \{s, d\} = \{mmss, mfss, fmss, ffss, mmsd, mfsd, fmsd, ffsd, mmms, mfms, fmsd, fffs, mmds, mfd, fmds, fffs, mmdd, mfdd, fmdd, ffdd\}$
 $= \{mbs, fbs, mbd, fbd, mzs, fzs, mzd, fzd\}.$

Figure 7 displays the mapping of the American/English kinship terms onto the usual genealogical grid as predicted from the construction of kin type products for kin terms based on the symbol structure and the above instantiation of the atomic kin terms. The set of predicted mapping is completely correct, hence the construction has succeeded in accounting for the distribution of kin type products for the kinship terms. The formalism based on viewing the kinship terminology as a symbol structure thus includes within it the results obtained through the formalism of rewrite rules, hence is a more encompassing theory, at least for the American/English terminology.

The construction not only provides a Model_T isomorphic to the Model_D and accounts for the distribution of kin type products over the kin terms, but also accounts for a property of the American/English kinship terminology that heretofore has been considered either an anomaly -- namely the lack of the “-in-law” suffix on the terms used to refer to one’s parent’s siblings -- or problematic by virtue of the way in which the Uncle/Aunt terms depend upon a disjunctive definition from a genealogical perspective.

The “anomaly” is found to be explicable as a property deriving from the properties of the symbol structure that has been constructed. A logical implication of Equation (6) is that the equations, Spouse o Uncle = Aunt (“Spouse of Uncle is Aunt”) and Spouse of Aunt = Uncle, must be true.²³ The same logic applies to the kin terms Great ... Great Uncle and Great ... Great Aunt. Consequently, the way in which the consanguineal kin term, Uncle (Aunt) is also used for affinal (genealogical) relatives is explicable as kin term usage consistent with the underlying logic of the kin term structure. There is no need to appeal to non-terminological properties to account for the seeming anomaly of not using a term with the suffix “-in-law” for Spouse of Aunt (Spouse of Great Aunt, etc.)

²³ This may be shown as follows: Spouse of Uncle/Aunt = Spouse of Child of Parent of Parent = (Spouse of Child of Parent) of Parent = (Child of Parent of Spouse) of Parent [from Equation (6)] = Child of Parent of (Spouse of Parent) = Child of Parent of Parent [from Equation (5)] = Uncle/Aunt.

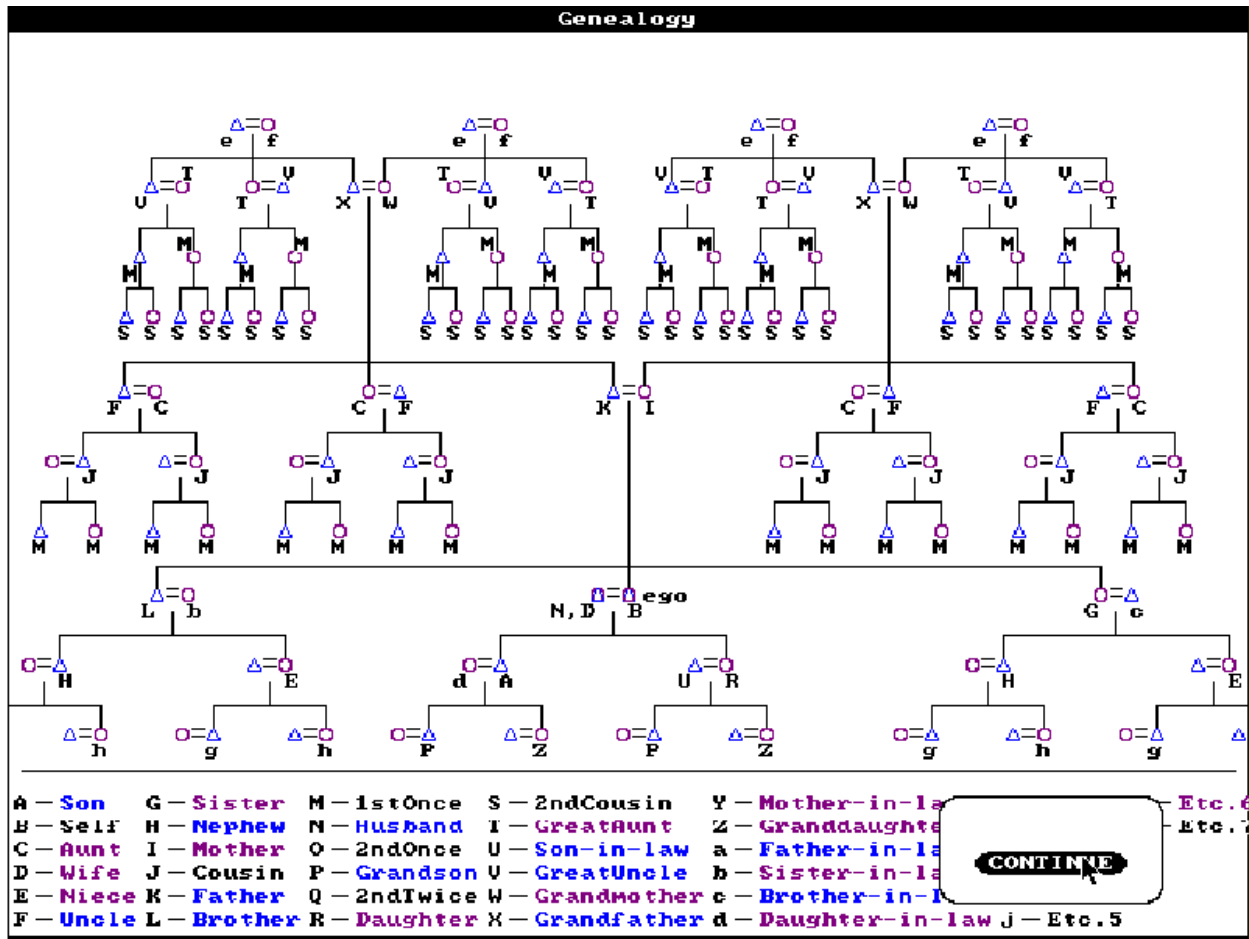

Figure 7: Genealogical diagram for the AKT as predicted from the algebraic structure shown in Figure 5 and the mapping from symbols to kin types defined by Self $\rightarrow \{ego\}$, Parent $\rightarrow \{m, f\}$, Child $\rightarrow \{d, s\}$ and Spouse $\rightarrow \{w, h\}$.

and Spouse of Uncle (Spouse of Great Uncle, etc.), contrary to the argument of Schneider (Schneider, 1980: 107, n. 7) that the lack of an -in-law suffix has to do with affect.²⁴

The disjunctive definition, with its attendant problems as discussed extensively by D'Andrade (1970), arises only because of features of the genealogical grid onto which kin terms are mapped. The local, structural relation of Aunt to Uncle is the same as the structural relation of Mother to Father, namely both pairs of terms satisfy the equation, Spouse of $X = Y$.

²⁴ It could be countered that the affect argument is valid since the derivation of the equation Spouse of Uncle/Aunt = Aunt/Uncle can also be reversed so as to derive the sibling-in-law equation. This raises the question of which of the two equations, Spouse of Uncle/Aunt = Aunt/Uncle and Spouse of Sibling = Sibling of Spouse has priority. The latter equation seems the more probable candidate since it is needed for the Sibling-in-law term to be self-reciprocal in parallel with the fact that the Sibling term is self-reciprocal, and it is consistent with Equations (3) and (4) that limit the extensiveness of the affinal portion of the structure for the American/English kinship terminology. Without the Spouse of Sibling = Sibling of Spouse equation, all products of Spouse with kin terms other than Parent, Parent of Parent, . . . and Child, Child of Child, . . . would lead to distinct symbols that would be part of the affinal portion of the structure. Equations (3) and (4) limit the affinal portion linked to the Spouse term to just Parent of Spouse and Sibling of Spouse.

Disjunctiveness does not arise for the Mother/Father pair in the genealogical grid only because of the assumption that in the genealogical grid “If *a*’s-child- is *c*, and *b*’s-child-is *c*, then *a*’s-spouse-is *b* (all children are legitimate)” (D’Andrade 1970: 92); that is, within the genealogical grid ego’s mother’s spouse must be ego’s father, where ego’s father is the genitor of ego. Further, the term Stepfather prevents the disjunctivity that would arise in the case when ego’s mother has, in fact, divorced and remarried if the term Father were to be used by ego for ego’s mother’s new husband, for then Father could refer either to ego’s genitor or ego’s mother’s husband (Read 1984). Thus the problem with disjunctivity that has been associated with the Aunt/Uncle terms is not a feature of these terms, but simply a consequence of the way in which the symbol structure interfaces with the genealogical grid.²⁵

The Logic Behind Kinship Terminology Properties

As has been shown with the American/English kinship terminology, modeling a kinship terminology as a symbol structure appears to be an effective way to account for properties of a kinship terminology. In this section we will outline, for another terminology, a wide range of features that seem to be the logical consequence of the underlying structure. The terminology to be considered is that of the Shipibo Indians of Peru. The example will also illustrate the way in which terminologies that are radically different at the surface level of kin terms may share structural commonality at a deep, structural level.

The Shipibo terminology (see Figure 8 for a kin term map representation of the Shipibo consanguineal terminology) has a number of features that make it inconsistent with Murdock’s classification of kinship terminologies (Behrens, 1984: 139-147). At the grandparental level the terminology takes on a classificatory aspect with the same kin terms (*Papaisi* for males and *Yoshan* for females) used for siblings of (genealogical) grandfather and grandmother. The “sibling” terms (see Table 2) are used for all genealogical cousins (parallel or cross) and the terms used for children of “brother”/ “sister” are distinguished by sex of speaker but not by sex of child. Similarly, the term for children of ego are not distinguished by sex and are referred to by the single term, *Bake*. At the grandchild level there is a single term, *Baba* used for all persons for whom ego would use a kin term at this generational level

The pattern for the kin terms where sex of speaker is a feature is shown in Table 2.

Table 2: Shipibo Kinship Terms Dependent upon Sex of Speaker

Gloss	Female speaker	Male speaker
“Uncle”	<i>Koka</i>	<i>Epa</i>
“Aunt”	<i>Huata</i>	<i>Nachi</i>
“same sex sibling/cousin”	<i>Pui</i>	<i>Pui</i>
“opposite sex sibling/cousin”	<i>Huetsa</i>	<i>Huetsa</i>
“child of same sex sibling/cousin”	<i>Ini</i>	<i>Nosha</i>
“child of opposite sex sibling/cousin”	<i>Chio</i>	<i>Pia</i>

²⁵ Disjunctivity arises in the symbol structure when the binary product maps a pair of symbols, *X* and *Y*, to more than one symbol. An example is the term, 2ndCousinOnceRemoved in the American/English terminology since Child of 2ndCousinOnceRemoved = 2ndCousin or 2ndCousinTwiceRemoved (see Figure 4).

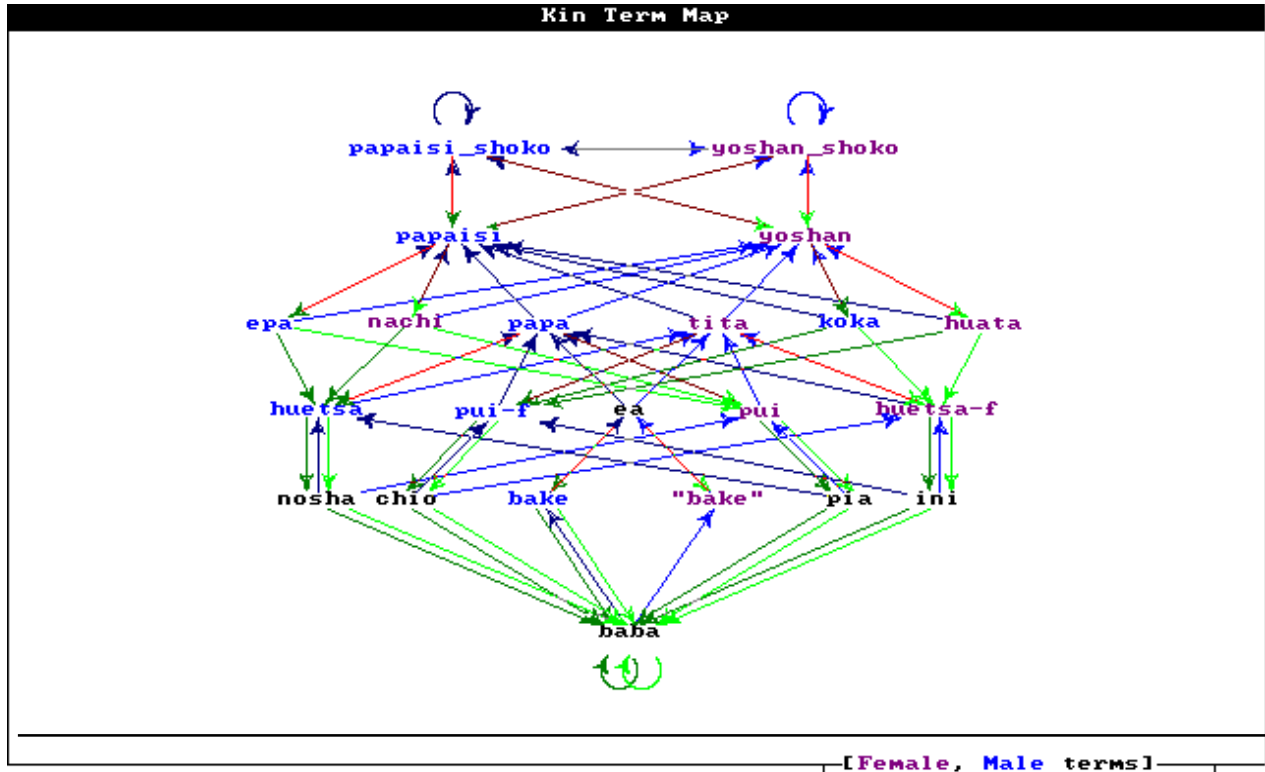

Figure 8: Kin term map for the Shipibo terminology. Upward arrows represent taking products with the atomic kin terms *papa* (= “Father”) and *tita* (= “Mother”). Downward arrows represent taking kin term products with the kin term *bake*. The “-f” indicates a kin term used by a female speaker. The same term without the “-f” is the kin term used by a male speaker. The terms *epa* and *nachi* are used by male speakers and the terms *koka* and *huata* are used by female speakers. The terms *bake* and “*bake*” are a single kin term but with two forms to indicate that there is a covert, sex-marked form of *bake* (= “Child”).

Similarly, the term for children of ego are not distinguished by sex and are referred to by the single term, *Bake*. At the grandchild level there is a single term, *Baba* used for all persons for whom ego would use a kin term at this generational level

The pattern for the kin terms where sex of speaker is a feature is shown in Table 2.

Table 3: Shipibo Kinship Terms Dependent upon Sex of Speaker

Gloss	Female speaker	Male speaker
“Uncle”	<i>Koka</i>	<i>Epa</i>
“Aunt”	<i>Huata</i>	<i>Nachi</i>
“same sex sibling/cousin”	<i>Pui</i>	<i>Pui</i>
“opposite sex sibling/cousin”	<i>Huetsa</i>	<i>Huetsa</i>
“child of same sex sibling/cousin”	<i>Ini</i>	<i>Nosha</i>
“child of opposite sex sibling/cousin”	<i>Chio</i>	<i>Pia</i>

The analysis of the Shipibo terminology establishes that its atomic kin terms are the terms *Ea* (“Self”), *Papa* (“Father”) and *Tita* (“Mother”) along with the single reciprocal term, *Bake*

(“Child”) for *Papa* and *Tita* (Read and Behrens 1990; Read n.d.). In place of the equation, Parent o Child = Self, the Shipibo terminology has the analogous equations *Papa o Bake = Ea* for male marked kin terms and *Tita o Bake = Ea* for female marked kin terms. It follows that the underlying structure for the male marked (or for the female marked) kin terms is isomorphic to the consanguineal structure for the underlying structure for the American/English kinship terminology based on the atomic terms, Self and Parent (and reciprocally, Child) and the structural equation Parent o Child = Self. The Shipibo terminology differs from the American/English terminology, however, by use of the equations

$$Bake \circ Papa \circ Papa \circ Papa = Papa \circ Papa$$

and

$$Bake \circ Bake \circ Papa \circ Papa = Bake \circ Papa$$

for reducing the male substructure generated through use of the kin terms *Ea*, *Papa* and *Bake*, and by use of the equations

$$Bake \circ Tita \circ Tita \circ Tita = Tita \circ Tita$$

and

$$Bake \circ Bake \circ Tita \circ Tita = Bake \circ Tita$$

for reducing the female substructure generated through use of the terms *Ea*, *Tita* and *Bake*. The effect of the first equation in each of these two sets of equations is to collapse what would be collateral kin terms onto lineal kin terms, hence giving the terminology a classificatory aspect. The effect of the second equation in each pair of equations is to identify “Cousin” terms with “Sibling” terms. It is these four equations, along with male marked and female marked atomic terms, that accounts for the structural differences between the American/English and the Shipibo terminologies despite sharing a common structure at the deep level of atomic terms and structural equations, namely Parent o Child = Self, for the American/English terminology and its sex marked form, *Papa o Bake = Ea*, for the male marked Shipibo kin terms (or, equivalently, the equation, *Tita o Bake = Ea*, for the female marked Shipibo kin terms).

Since the Shipibo terminology has atomic kin terms that are already sex marked, there is no need for a rule that identifies when kin terms will be sex marked. Further, the structural position for a “Cousin” term is identified with the structural position for a “Sibling” term, hence there is no rule for labeling of “Cousin” terms as occurs in the American/English terminology. The “affinal equation,” “Sibling of Spouse” = “Spouse of Sibling,” also applies to the Shipibo terminology.

Under the instantiation

$$Ea \rightarrow \{\text{ego}\},$$

$$Papa \rightarrow \{f\},$$

$$Tita \rightarrow \{m\}$$

and

$$Bake \rightarrow \{s, d\}$$

the distribution of kin type products over the kin terms in the Shipibo terminology is predicted with complete accuracy (Read n.d.). In addition, as the process of constructing the full Shipibo terminology unfolds, the features of the terminology regarding sex of speaker shown in Table 2 are found to arise as a way to resolve what otherwise would be an anomaly when the genealogical interpretation of the kin terms is worked out under the instantiation given above. Briefly, only when ego is bifurcated into male ego and female ego will there be, for all of the kin terms, a consistent instantiation of the kin terms. More precisely, when the above instantiation is used to

map kin terms to kin type products, more than one kin term is mapped to a single kin type product for some of the kin terms.²⁶ That anomaly is removed when ego is either labeled male or labeled female. That is, when ego is labeled male, say, then the mapping of kin terms to kin type products maps at most one kin term to a kin type product. Further, for those terms where the two mappings so constructed (one based on a male ego, the other based on a female ego) each yield the same kin type product for a kin term, the sex of ego does not affect the usage of those particular terms. The terms so identified in the algebraic analysis are precisely the terms where, in fact, kin term usage is independent of the sex of speaker. In addition, all of the terms where the two mappings differ with regard to the kin type associated with a kin term are precisely those terms for which the sex of speaker does, in fact, make a difference in usage. Finally, the number of distinct terms so determined through the algebraic construction matches the empirical data. More precisely, the algebraic construction implies that there will be two “sibling” terms with the usage of these two terms dependent upon the sex of speaker. The Shipibo terminology does have two “sibling” terms where the usage depends upon the sex of speaker (see Table 2). Further, the algebraic construction implies that there will be four terms (two marked as male terms and two marked as female terms) whose usage depends upon the sex of speaker and applicable to persons who are siblings of parents. In fact, the Shipibo terminology has four such terms distinguished by sex and whose usage depends upon the sex of speaker (see Table 2). Finally, the analysis predicts that there will be four terms used for “child of sibling,” dependent upon sex of speaker for usage and the Shipibo terminology has four such terms (see Table 2). In all cases the pattern of usage predicted from the structural analysis matches the actual pattern of (proper) usage.

To summarize, it is logically necessary that certain of the symbols distinguished in the symbol structure have instantiation (in terms of kin types) through use of a sex marked ego to avoid the problem of having more than one kin term being mapped to the same kin type and conversely, all kin terms where sex of speaker is identified as critical to the usage of a kin term are so identified through the structural analysis of the terminology. Note that the instantiation does not assume sex-marked egos for the instantiation of the term, *Ea*. Instead, the bifurcation of ego into male ego and female ego arises in order for the instantiation to be carried out fully in a consistent manner so that no more than one kin term is mapped to a single kin type product.

Just as the lack of an “-in-law” suffix for the term corresponding to Spouse of Aunt or Spouse of Uncle is explicable through the logic of the symbol structure for the American/English kinship terminology, the dependence of terms such as *Pui* and *Huetsa* on sex of speaker for their usage in the case of the Shipibo is also explicable through the logic of the symbol structure underlying the Shipibo terminology and the instantiation of the kin terms via kin types. Rather than viewing these as features that require their own, specific explanation, they are, instead, a consequence of how a kin term structure is generated and instantiated. The Shipibo example is

²⁶ The same problem arises with the American/English terminology for the Spouse terms, Husband and Wife. Usage of these two terms depends upon sex of speaker. The algebraic construction maps both of these terms to the kin type product, ego’s spouse, when ego has no sex specification. By introducing the sex of ego the anomaly is removed and the algebraic construction then maps Husband to female ego’s spouse and Wife to male ego’s spouse, but sex of ego makes no difference in the mapping of any of the other kin terms to kin types. Hence the fact that the terms/symbols, Husband and Wife, are mapped to kin types in a manner dependent upon sex of speaker can be derived solely from the algebraic construction, the instantiation of the atomic terms, and a principle that when more than one kin term is mapped to a kin type (according to the algebraic structure and the instantiation), then ego should be given sex marking, thereby allowing usage of some kin terms to depend upon sex of speaker.

particularly striking in that the terms where the sex of speaker affects kin term usage can be recovered solely from the logic of the symbol structure in conjunction with logical consistency in the instantiation of the kin terms via genealogical father and genealogical mother.

The Shipibo example is of particular interest as it implies that while the symbol structure can be identified and analyzed without reference to a genealogical interpretation of kin terms, and while the kin terms that depend upon sex of speaker for their proper usage are distinguished as distinct terms through the *logic* of this symbol structure, the *usage* of the latter set of terms, with their dependency on sex of speaker in some cases, arises through a genealogical instantiation of the kin terms. The symbol structure distinguishes the terms, but the need to identify sex of speaker as a feature for their proper usage does not arise until a genealogical instantiation is made of the kin terms and the logic of that instantiation as implied by the symbol structure is worked out. The Shipibo example suggests that one property of kinship terminological systems may be consistency with genealogical tracing. However, the direction of the consistency is from terminological structure to instantiation of the atomic kin terms using primary kin types, not from a genealogical “grid” to kin terms as argued by Lounsbury and Scheffler.

Instantiation of Symbols and Kinship

The last observation suggests that one’s kin are determined through the instantiation of the symbols in the symbol structure. Contrary to Rivers’ claim that kin terms are defined through genealogical specification, the kin terms have relationships as symbols via the symbol structure of which they are a part. It is the symbol structure that then determines which kin terms correspond with what kin types when an instantiation of the atomic kin terms is made using genealogical father and genealogical mother (see Figure 9). Further, as noted above with the Friend/Enemy example, a kinship terminology can have alternative (cultural) instantiations so long as the instantiation is carried out in a manner consistent with the logic of the terminological structure.²⁷ For example, were we to (culturally) instantiate the kin term, Child, in the American/English terminology by “adopted child” in addition to “birth child,” consistency would require that a person who is an adopted child would reckon kin terms in a manner no different than a birth child. Thus a “birth child” would call an “adopted child” by the kin term Brother or Sister; a person a “birth child” would call Aunt would call the “adopted child” by the kin term Nephew or Niece, and so on.²⁸

²⁷ Lehman has also noted the role of consistency with kin term calculations as a criterion for being a member of one’s kinship domain, but from the direction of adducing that “quite commonly ... if a kin-term has a lexical definition such as to include non-genealogically related persons (say to 'ego'/speaker), then deducible other relations within that kin-structure *generally* fail to carry through” (Lehman, in Kronenfeld 2001, n.3, emphasis added). Lehman does not say “always” and uses the qualifier “generally” for the obvious reason that there are other examples where the “deducible other relations” do carry through. I suggest that rather than serving as evidence for the primacy of a morphism from PGS to a kin term structure as argued by Lehman (note that the morphism in question was hypothesized in Lehman and Witz (1974) but not constructed by them for any terminology), the criterion of “deducible other relations” serves as a means to determine when the instantiation of a kin term does or does not belong to the domain of culturally defined kin. Thus my courtesy aunt (Lehman, in Kronenfeld 2001, n. 3) is not in the domain of my kin, for if she refers to alter by the kin term Mother I do not (properly) refer to alter by the kin term Grandmother, whereas (for example) if I refer to alter as Father, my (adopted) child would refer to alter as Grandfather, hence my (adopted) child is in the domain of my kin.

²⁸ It might be objected that the “Step-“ and “Half-“ form of kin terms in the American/English terminology would seem to violate consistency in application. However, as argued by Read (1984), the “Step-“ and “Half-“

If, then, we view one's kin as those persons for whom kin terms may properly be used, where "properly uses" is determined through culturally specified rules of instantiation for the kin terms, what does this imply about genealogy and genealogical tracing with regard to kinship? As Parkin (Parkin, 1996) has commented, genealogical tracing is a way to provide greater specificity of the relationship of one person to another than can be done through specification via the kin term categories. Genealogical tracing is also something that most people find quite easy to do without detailed instruction (Lehman and Witz. 1974). But genealogical tracing and the genealogical grid that has been the basis of rewrite rule analysis are not the same thing, and failure to distinguish between these two constructs has created a confusion between the fact that tracing only depends upon recursive use of dyadic links, whereas the genealogical grid is a symbol structure constructed from primitive elements, a product (kin type products) and structural equations (Read 2001), hence is a structure whose relevance to a given cultural context must be demonstrated and not assumed. Genealogical tracing is dependent only upon a culturally specified (dyadic) link of each person to a male person and to a female person purportedly in some kind of ancestor/descendant relationship. Whether the link represents genetic father/genetic mother, genitor/genetrix, *pater/mater*, or whatever is not critical for the *process* of tracing. Tracing uses simple recursion from an initial person along whatever paths are identified as one repeatedly repeats the process of linking the current, focal person to a male person or to a female person by the culturally specified criterion for asserting a pair of dyadic links between the pair of persons in question. Whether the tracing constitutes *genealogical* tracing depends upon a logic with regard to what claims about linkages are valid with regard to genealogical tracing, e.g., the same person cannot be claimed to be both male and female in two dyadic linkages (see Lehman and Witz (1974); Atkins (1974) for a more detailed discussion of the logic of genealogical tracing).

Hence it suffices for genealogical tracing to identify a genealogical father and a genealogical mother, as suggested by Lehman (in Kronenfeld 2001), for each person so that tracing may be done recursively. The criterion by which someone is culturally specified to be a genealogical father or a genealogical mother is not needed for the process of genealogical tracing.

In contrast, the genealogical grid is based on the set of primitive symbols, {*ego, f, m, b, z, s, d*}, the kin type product, and the structural equations

$$fs = ms = b, \tag{7}$$

$$fd = md = z,^{29} \tag{8}$$

$$sf = df \tag{9}$$

$$sm = dm \tag{10}$$

nomenclature appears to be a way to resolve the intersection of the kinship terminology with actual situations that violate the premise underlying marriage, namely that a marital union is, conceptually permanent. The "Step-" and "Half-" "rules" are not of the same nature as the structural equations as their logic is not extended to all symbols. One does not have a StepGrandfather, for example. Rather, Father of StepFather = Grandfather and so the Step- and Half- prefixes provide alternative symbols for the structural positions labeled by the term without the prefix. The products of kin terms with the Step- and Half- terms are calculated as if one were using the non-prefixed part of the Step- or Half- term. Note that the same observation is not true for a construction such as "den mother" since the Father of den mother is not Grandfather. Thus "den mother" is not a kin term according to the algebraic representation of the American/English kinship terminology.

²⁹ Equations (7) and (8) are the same as the "Half-Sibling Rule" used in rewrite rule analysis.

$$bz = z$$

(11)

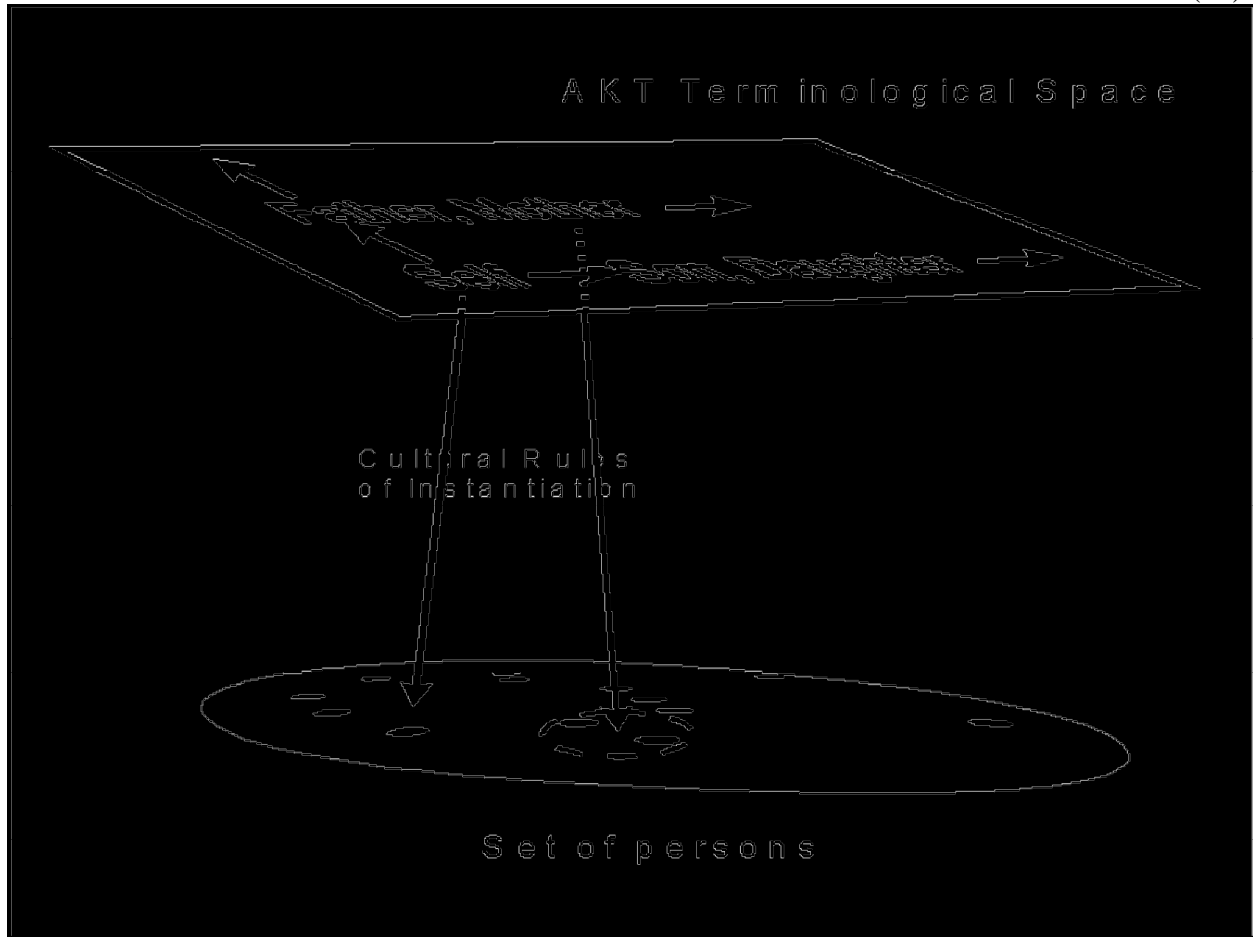

Figure 9: Diagram illustrating the mapping of AKT kin terms viewed as symbols onto a set of persons via cultural rules that specify how the symbols should be instantiated. The left arrow indicates that the kin term, Self, has been mapped to a person (ego), and the pair of symbols, Mother and Father, have been mapped to two persons circled with a dashed line. No *a priori* claim is made as to the genealogical relationship (if any) of the latter two persons to ego; e.g., the two persons might be the two persons ego calls Mother and Father, respectively, by virtue of adoption.

$$zb = b \tag{12}$$

$$sb = s = db \text{ and reciprocally, } bf = f = zf \tag{13}$$

and

$$sz = d = dz \text{ and reciprocally, } bm = m = zm^{30} \tag{14}$$

³⁰ Equations (9) – (14) are considered axiomatic by Scheffler and Lounsbury: “It may be regarded as an axiom of all kinship systems we know of that, e.g., the parent of a sibling is a parent or step-parent, and conversely, the sibling of a child is a child or step-child. Similarly, the sibling of a sibling is regarded as a sibling ...” (1971: 128, note).

(see Read (2001) for a more formal discussion of the genealogical grid and its relationship to tracing via genetic father/mother and *genitor/genetrix*). Further, the kin types f and m are generally assumed to be the genitor and genitrix of ego, respectively, thereby also introducing, for the genealogical grid, a presumption about the universality of genitor and genitrix as culturally salient categories -- a universality that is not needed for genealogical tracing.

Unlike genealogical tracing, the genealogical grid³¹ is an abstract structure that requires instantiation for its usage. It is the latter that is problematic for claims about the universality of the genealogical grid. Do all cultures both conceptualize a genealogical grid and provide rules of instantiation for its primitive elements? Instantiation is not automatic by virtue of procreation unless one also claims that the male and female involved in coitus are, necessarily, the objects for the instantiation of, say, the primitive symbols, f and m . That, of course, is the claim made by Scheffler and Lounsbury. By making that claim, Scheffler and Lounsbury neatly sidestepped the problem of instantiation of the symbols used in the genealogical grid. But the ethnographic evidence, as discussed above, seems to suggest that that is too strong a claim. If so, the genealogical grid is not universal and so kinship cannot be constructed on the basis of the properties taken as underlying the genealogical grid. Rejection of the genealogical grid does not, however, deny genealogical tracing. The genealogical grid, though, *is* necessary for the argument that kin terms are labels for classes of kin type products. The class label argument does not, of course, apply to genealogical tracing.

What we seem to be left with, then, is two levels at which relations between individuals are considered. First is the level of relations identified through genealogical tracing (however the dyadic linkages might be culturally defined) and where there is no *a priori* structure other than the dyadic relations upon which the tracing is based. We can identify the male and female used in genealogical tracing as the genealogical father and the genealogical mother, respectively. The second is the highly structured set of relations determined through the kinship terminology.³² The

³¹ It should be noted that the genealogical grid and the structure referred to by Lehman and Witz (1974) as the Primary Genealogical Space (PGS) (see also n. 1, Lehman, in Kronenfeld 2001) are not isomorphic. Whereas PGS is (roughly) a product structure based on four relations that ensure consistency with genealogical tracing (see Definition 2.2, Lehman and Witz 1974), the genealogical grid is a homomorphic image of PGS whose structure is reduced from the structure of PGS via Equations (9 – 14). Lehman provides the useful clarification that PGS “is the cognitive space within which, alone, such reckoning [i.e., genealogical tracing] is to be understood” (n. 10, in Kronenfeld 2001).

³² Distinguishing between relations determined through genealogical tracing (excluding the genealogical grid), on the one hand, and relations determined through the kin term structure and instantiation of the kin terms, on the other, also offers a way to resolve the various claims about the relationship between genealogy and kinship terminology. As shown in Read (2001), the kinship terminology structure may be viewed as an abstraction from the kind of relationship upon which genealogical tracing is based, hence in this sense genealogical tracing is prior to kin term reckoning. At the same time, the abstraction removes genealogy and genealogical tracing as a feature of a kin term structure, thus kin relations, as argued in Read (2001), can be defined via the kin terminology structure and its instantiation without *necessary* reference to genealogy and genealogical tracing (though as noted by Lehman, in Kronenfeld 2001, empirically there is no known society that excludes all aspects of genealogical tracing from the domain of kin determined through instantiation of the generating kin terms).

The same abstraction also implies that the morphism *hom* from PGS to a kin terminology space (Lehman and Witz 1974, Lehman in Kronenfeld 2001) must be determined by *first* constructing the inverse morphism, hom^{-1} from the kin terminology space into PGS (e.g., the mapping from the kin terminology onto kin type products displayed in Figure 7) and *then* defining $hom = (hom^{-1})^{-1}$. The information for constructing *hom* can only come from the structure of the kinship terminology and instantiation of the generating elements via the underlying relations used to construct

latter intersects with the former in that the set of persons identified through instantiation of the symbols in the kinship terminology intersects in a non-empty manner with the set of persons identified through genealogical tracing – hence the possibility of simultaneous use, as discussed by Parkin (1996), of both categorical specification via kin terms and a more detailed specification based on genealogical tracing.

Finally, the instantiation of the kin terms allows for flexibility in term of who are considered kin within the framework of the kinship terminology. Instantiation must be culturally specified and while there may be a consistency constraint as discussed above with regard to how kin terms are used once the instantiation is specified, there is no constraint from the viewpoint of the symbol structure as to the content of the instantiation. The only constraint on content relates to what, culturally, might be deemed as a valid instantiation, hence there is no need to introduce concepts such as metaphorical extension or fictive kin when the instantiation includes persons without a known (or even without any) genealogical relationship to ego. Or, the criterion for instantiation may use an aspect unrelated to genealogy, such as residence as seems to occur with some of the groups in New Guinea (Langness 1964). Instantiation can both change over time (c.f. Strathern 1992) and use different rules at the same point in time. The latter allows for a context based specification of who are one's kin, hence a way to accommodate observations such as those of A. Strathern who noted that for the *Melpe* of New Guinea, in a ceremonial context a speaker would assert he is a "true' cross-cousin because he lives near to his kin and is their regular and generous exchange partner" (1973: 32), yet in other contexts the same person might assert that someone "is not my true (i.e. immediate genealogical) cross-cousin, we call each other by this term only because exchange pigs and shell valuables" (1973: 32).

PGS, hence *hom* is a derivative, and not a primary property of the relationship between genealogical tracing/PGS and the kinship terminology structure.

Consequently we have two, distinct, conceptual structures: one of genealogical tracing whose cognitive space is modeled through PGS, and the other the kin term structure whose cognitive space is modeled through the algebraic representation of the structure expressed through a kin term map. For these two structures, genealogical tracing is necessarily prior to the kin terminology structure in an ontological, but not a taxonomic, sense. The ontological priority of genealogical tracing seems to be expressed through the empirical fact that all societies include, but are not limited to, some aspect of genealogical tracing in the instantiation of the abstract cultural construct we refer to as a kinship terminology.

Appendix: Kin Graphs and Kin Term Maps

As noted by Kronenfeld, the kin term graph for the American Kinship terminology based on genealogical tracing is strikingly similar to the kin term map that displays the structural linkages among the kin terms (compare Figures 1-3, Kronenfeld, in Kronenfeld 2001 with Figure 5, Read, in Kronenfeld 2001). The resemblance is not coincidental but stems from the relationship between the structure of a kinship terminology and genealogical tracing produced via a genealogical instantiation of the generating terms for the structure descriptively expressed as a kin term map. This may be seen from the following observations.

The kin term map displays, directly, the structural relationships among kin terms without reference to genealogical tracing. In the kin term map kin terms are connected by arrows that represent the taking of kin term products; that is, to each arrow type (where an arrow type is its direction: up, down or sideways) is associated a kin term, K , so that in the kin term map an arrow of that type will begin at a kin term L and end at a kin term M when the kin term product, $K \circ L = M$, is culturally valid. For example, if the kin term Father is associated with an up arrow in the American/English Kinship Terminology, then an up arrow would connect each of the kin terms, Father and Mother, with the kin term Grandfather since, for kin terms, Father of Father = Grandfather = Father of Mother. That is, if ego properly refers to alter₁ by the kin term Father and alter₁ properly refers to alter₂ by the kin term Father, then ego properly refers to alter₂ by the kin term Grandfather, and similarly for the Father of Mother product (see Read, in Kronenfeld 2001, for a formal definition of a kin term product).

Once the genealogical instantiation of the kin terms associated with arrows is specified, the kin term that would (properly) be used by ego for alter may be determined from the genealogical connection between ego and alter through use of the kin term map. Thus, assuming the instantiation Father \rightarrow {genealogical father (gf)} and Mother \rightarrow {genealogical mother (gm)}, Grandfather = Father of Father, Father of Mother \rightarrow {gf} x {gf}, {gf} x {gm} = {gf of gf, gf of gm} = {gf's gf, gm's gf} = {genealogical father's genealogical father, genealogical mother's genealogical father}. Observe that it is the structural relationships among the kin terms, Father, Mother and Grandfather, as displayed in a kin term map along with the genealogical instantiation of the kin terms, Mother and Father, that leads to the genealogical specification of the kin term, Grandfather, as the term (properly) used by ego for those alters whose genealogical relationship to ego is either ego's genealogical father's father or ego's genealogical mother's father, and not the converse.

Once the genealogical specifications for the kin terms have been worked out (whether as an analytical exercise or as knowledge embedded in the kinship terminological system and elicited from informants, say, via Rivers' Genealogical Method), it is possible to begin with the genealogical specifications and construct the (genealogically specified) relationships among the kin terms. But in so doing, we are not establishing the primacy of genealogical specification of kin terms but taking advantage of the groupings of genealogical relationships produced when the kin terms are mapped into the (conceptual) space of genealogical relations (Lehman's PGS) in accordance with the logic underlying the kin term map. Consequently, we can arrive at similar kin term diagrams via two routes: (1) directly through construction of the kin term map as a structure linking kin terms via the kin term product, or (2) indirectly through the genealogical

specification for each kin term elicited from native knowledge about kin terms since the genealogical tracing has its expression via kin terms in the genealogical instantiation of the kin terms associated with the structuring arrows in the kin term map. Note that the instantiation need not be limited to genealogical tracings, hence the genealogical instantiation of kin terms will in many instances, as argued by Read (2001), only include a portion of the kinship domain produced through the kinship terminology and its culturally specified instantiation.

The structurally equivalent kin type products used to include different kin type products in the same box (see Kronenfeld's discussion of Gould's kin graph method, in Kronenfeld 2001) do not arise from the properties of genealogical relations, but from structural properties expressed in the kin term map. Gould's kin graph, like the kin term map, is a data model, $Model_D$ (Read, in Kronenfeld 2001). Further, the kin graph need not be isomorphic to the kin term map as it uses genealogical tracing, rather than kin term products, for connecting the boxes in the kin term graph. However, the kin term graph can be converted into a kin term map once it is recognized that the form of genealogical tracing used for constructing the kin term graph can be linked to the form of genealogical tracing derived from the structure displayed in the kin term map when genealogical instantiation is made of the terms for which the arrows represent the result of taking kin term products. For example, the double arrows in Figure 1 (Kronenfeld, in Kronenfeld 2001) for the American/English Terminology can be replaced by a single arrow representing kin term tracing with the kin term, Parent, since in all instances of connected boxes in Figure 1 there are double arrows that represent tracing with genealogical father and genealogical mother (see also Atkins 1974). After making this replacement, all the arrows in Figure 1 for the kin term graph have their counterparts in Figure 5 for the kin term map. Next, if the boxes in the kin term graph containing pairs of kin terms separated by a vertical line (see Kronenfeld's Figure 1) are labeled by a single, non-sex marked covering term (e.g., Parent, in the case of the box containing M|F), these boxes would now have content matching the labeling of nodes in the kin term map. At this point Kronenfeld's Figure 1 would now almost be isomorphic with Read's Figure 5 (in Kronenfeld 2001). The exception would be the up arrows connecting terms such as Child with Self, Grandchild with Child, Sibling with Parent, and so on, that are part of the kin term map. These arrows need special comment as they relate to a property of a kin term map excluded by genealogical tracing from the kin term graph. The excluded property for the kin term graph is genealogical tracing that "double backs".

As do Southwold (1971) and Atkins (1974) in their formalism, Gould excludes tracing that "doubles back" and includes the same person more than once. The latter precludes the reverse of the arrows in Kronenfeld's Figure 1. Kin term products, though, are about relations among kin terms, not properties of genealogical tracing. The *kin term* product, Parent of Grandchild, for example, is culturally salient for cultural users of the AKT, hence is a kin term property that should be included in a complete $Model_D$ for the American/English kinship terminology and so products of this kind are included in the kin term map. Consequently, the kin term map is more inclusive of relations among *kin terms* than is the kin term graph. Further, it is only when this additional information about the relationships among kin terms (that is, products whose result would imply reverse genealogical tracing when the kin term relations are given instantiation via genealogical tracing) is included in the $Model_D$ that the algebraic structure underlying a $Model_D$ becomes evident. In the kin term graph, products of symbols such as Parent of Grandchild have no representation even though the kin term product has cultural salience. The rationale for excluding "reverse" genealogical tracing lies in the way reverse genealogical tracing can create

loops by returning back to the same person. Thus the exclusion stems from complications that would arise were one to allow unlimited genealogical tracing. Hence the kin term graph is not intended to be a model for genealogical tracing, but a model of relations among kin terms and to achieve the latter some tracings are excluded for reasons unrelated to genealogy, per se. In other words, it is the relations among the kin terms that, ultimately, is the arbiter for how the kin term graph is constructed. The kin term map presents those relations directly, rather than indirectly via a restricted form of genealogical tracing.

The same problem does not arise with the kin term map as the kin term products are ultimately defined, at a deep structural level, with respect to a particular domain of kin terms (see Read 1984, nda; Read and Behrens 1990); e.g., the kin term product Parent of Grandchild is defined with respect to the domain of consanguineal kin terms and so Parent of Grandchild = Child is true in the domain of consanguineal kin terms as the kin term, Child-in-law, is excluded from that domain. The term, Child-in-law, would only arise when the domain is expanded to include an affinal space and in the expanded space one would have a product equation such as Spouse of (Parent of Grandchild) = Spouse of Child = Child-in-law but not the product equation, [**] (Spouse of Parent) of Grandchild = Parent of Grandchild = Child \neq Child-in-law as the Parent of Grandchild product is calculated first in the consanguineal space and then the Spouse product is calculated.

Finally, once the “reverse” arrows are also added to Figure 1 (along with the replacement of the double arrows and the labeling of the boxes with non-sex marked kin terms based on the pair of terms contained in the box as discussed above), the kin term graph is now isomorphic to the kin term map shown in Read’s Figure 5. Hence, although the kin term map and the kin term graph appear, at first glance to make fundamentally different assumptions (relations among kin terms versus genealogical tracing), the one kind of diagram can be translated into the other by making use of the analytical/cultural results that link the logic of a kin terminology structure to the logic of genealogical tracing via the genealogical instantiation of the generating symbols for the kin terminology structure viewed as a logically structured symbol system.

REFERENCES CITED

- Atkins, J. R. (1974). ‘On the Fundamental Consanguineal Numbers and Their Structural Basis’. *American Ethnologist*, 1, 1-31.
- Austen, L. (1934). ‘Procreation among the Trobriand Islanders’. *Oceania*, 5, 112-113.
- Barnard, A., and Good, A. (1984). *Research Practices in the Study of Kinship*. London: Academic Press
- Beattie, J. (1964). ‘Kinship and Social Anthropology’. *Man*, n.s., 13, 475-476.
- Behrens, C. (1984). *Shipibo Ecology and Economy*. Diss. Los Angeles: UCLA.
- Bourdieu, P. (1990). *The Logic of Practice*. R. Nice, trans. Stanford University Press: Stanford.
- Buchler, I., and Selby, H. (1968). *Kinship and Social Organization: An Introduction to Theory and Method*. New York: The Macmillan Company.
- Chomsky, N. (1963). ‘Formal Properties of Grammars’, in *Handbook of Mathematical Psychology*, Vol. 2, eds. R. D. Luce, R. R. Bush, and E. Galanter. New York: Addison Wesley. pp. 323-341.
- D’andrade, R. (1970). ‘Structure and Syntax in the Semantic Analysis of Kinship Terminologies’, in *Cognition: A Multiple View*, ed. P. L. Garvin. New York: Spartan Books. pp. 87-143.
- Eggan, F. (1963). ‘Cultural Drift and Social Change’. *Current Anthropology*, 4, 347-355.

- Fortes, M. (1969). *Kinship and the Social Order*. New York: Aldine Publishing Co.
- Geertz, H., and Geertz, C. (1975). *Kinship in Bali*. Chicago: University of Chicago Press
- Godelier, M., Trautmann, T.R. and Tjon Sie Fat, F. E. (1998). 'Introduction', in Transformations of Kinship, eds. M. Godelier, T. R. Trautmann and F. E. Tjon Sie Fat. Smithsonian Institution Press: Washington D.C. Pp. 1 - 26.
- Goodale, J. (1971 (1994)). *Tiwi Wives*. Prospect Heights: Waveland Press.
- Goodenough, W. (1970). *Description and Comparison in Cultural Anthropology*. Cambridge: Cambridge University Press.
- Hammel, A. (1965). 'Introduction'. *American Anthropologist (Special Publication)*, 67(5 (part 2)), 1-8.
- Helmig, T. (1998). 'The Concept of Kinship in Yap and the Discussion of the Concept of Kinship'. *Journal of Anthropological Research*, 53, 1-15.
- Hirschfeld, L. A. (1986). 'Kinship and Cognition: Genealogy and the Meaning of Kinship Terms'. *Current Anthropology*, 27, 217-242.
- Kay, P. (1966). 'Comment on B. N. Colby, Ethnographic Semantics: A Preliminary Survey'. *Current Anthropology*, 7, 20-23.
- Keesing, R. (1975). *Kin Groups and Social Structure*. New York: Holt, Rinehart and Winston.
- Kelly, R. C. (1974). *Etoro Social Structure: A Study in Structural Contradiction*. Ann Arbor: University of Michigan Press.
- Kronenfeld, D., ed. (2001, in press) Special Issue of *Anthropological Theory*
- Langness, L. L. (1964). 'Some Problems in the Conceptualization of Highlands Social Structures'. *American Anthropologist*, 66, 162-182.
- Leach, E. R. (1958). 'Concerning Trobriand Clans and the Kinship Category "Tabu"', in *The Developmental Cycle in Domestic Groups*, ed. J. Goody. Cambridge: Cambridge University Press. pp. 120-145.
- Leach, E. R. (1966). 'Virgin Birth'. *Proceedings of the Royal Anthropological Institute*, 39-49.
- Leaf, M. (1971). 'The Punjabi Kinship Terminology as a Semantic System'. *American Anthropologist*, 73, 545-554.
- Lehman, F. K., and Witz. K. (1974). 'Prolegomena to a Formal Theory of Kinship', in *Genealogical Mathematics*, ed. P. Ballonoff. Paris: Mouton. pp. 111-134.
- Lehman, F. K., (2001 in Press) "Aspects of a Formalist Theory of Kinship: The Functional Basis of its Genealogical Roots and Some Extensions in Generalised Alliance Theory" in D. Kronenfeld ed., (2001 in press).
- Lounsbury, F. (1964). 'A Formal Account of Crow- and Omaha-Type Kinship Terminologies', in *Explorations in Cultural Anthropology: Essays in Honor of George Peter Murdock*, ed. W. H. Goodenough. New York: McGraw Hill. pp. 351-393.
- Lounsbury, F. (1965). 'Another View of the Trobriand Kinship Categories'. *Formal Semantic Analysis*, ed. E. A. Hammel. *American Anthropologist*, Special Publication 62((5), Part 2), 142-185
- Malinowski, B. (1913). *The Family among the Australian Aborigines*. London: University of London Press.
- Malinowski, B. (1932). *The Sexual Life of Savages in North-Western Melanesia*, 3rd edition. London: Routledge and Sons.
- Marshall, L. (1976). *The !Kung of Nyae Nyae*. Cambridge: Harvard University Press.

- Maxwell, J. (1996). 'Kin Terminology of an Inuit Community', in *North American Indian Anthropology: Essays on Society and Culture*, ed. R. J. DeMallie, and A. Ortiz. Norman: University of Oklahoma Press. pp. 25-48.
- McDougal, C. (1964). 'Juang Categories and Joking Relationships'. *Southwestern Journal of Anthropology*, 20, 207-230.
- Needham, R. (1962). 'Genealogy and Category in Wikmumkan Society'. *Ethnology*, 1, 223-264.
- Needham, R. (1971). 'Introduction', in *Rethinking Kinship and Marriage*, ed. R. Needham. London: Tavistock.
- Parkin, R. (1996). 'Genealogy and Category: An Operational View'. *L'Homme*, 139, 87-108.
- Powell, H. A. (1969). 'Genealogy, Residence and Kinship in Kiriwina'. *Man (n.s.)*, 4, 177-202.
- Powell, H. S. (1956). 'An Analysis of Present Day Social Structure in the Trobriand Islands'. Diss. London: University of London.
- Read, D. (1984). 'An Algebraic Account of the American Kinship Terminology'. *Current Anthropology*, 25, 417-440.
- Read, D. (1990). 'The Utility of Mathematical Constructs in Building Archaeological Theory', in *Mathematics and Information Science in Archaeology: A Flexible Framework*, ed. A. Voorrips. Bonn: Helos. pp. 29-60.
- Read, D. (2001). 'What is Kinship?', in *The Cultural Analysis of Kinship: The Legacy of David Schneider and Its Implications for Anthropological Relativism*, eds. R. Feinberg and M. Ottenheimer. Peoria: University of Illinois Press.
- Read, D. (n.d.) The Kinship Algebra Expert System Software Program. Manuscript.
- Read, D. and Behrens, C. (1990). 'KAES: An Expert System for the Algebraic Analysis of Kinship Terminologies'. *Journal of Quantitative Anthropology*, 2, 353-393.
- Rivers, W. H., R. (1924). *Social Organization*. London: W. J. Perry.
- Scheffler, H. W. (1972a). 'Baniata Kin Classification: The Case for Extensions'. *Southwestern Journal of Anthropology*, 28, 350-381.
- Scheffler, H. W. (1972b). 'Kinship Semantics', in *Annual Review of Anthropology 1*, ed. B. J. Siegel. Palo Alto: Annual Reviews. pp. 309-328.
- Scheffler, H. W. (1972c). 'Systems of Kin Classification: A Structural Typology', in *Kinship Systems in the Morgan Centennial Year*, ed. P. Reining. Washington, D.C.: Anthropological Society of Washington. pp. 113-133.
- Scheffler, H. W. (1976). 'The 'Meaning' of Kinship in American Culture: Another View', in *Meaning in Anthropology*, ed. K. H. Basso, and H. A. Selby. Albuquerque: University of New Mexico Press. pp. 57-91.
- Scheffler, H. W. (1978a). *Australian Kin Classification*. Cambridge: Cambridge University Press.
- Scheffler, H. W. (1978b). 'Reviews of the Demystification of Yap, by David Labby, and Pinikindu: Maternal Nurture, Paternal Substance, by Brenda Johnson Clay'. *American Ethnologist*, 5, 382-385.
- Scheffler, H. W. (1982). 'Theory and Method in Social Anthropology: On the Structure of Systems of Kin Classification'. *American Ethnologist*, 9, 167-184.
- Scheffler, H. W. (1984). 'Kin Classification as Social Structure: The Ambrym Case'. *American Ethnologist*, 11, 791-806.
- Scheffler, H. W. (1986). 'Comment on 'Kinship and Cognition: Genealogy and the Meaning of Kinship Terms' by Lawrence A. Hirschfeld'. *Current Anthropology*, 27, 233-234.

- Scheffler, H. W, and Lounsbury, F. (1971). *A Study in Structural Semantics: The Siriono Kinship System*. Englewood Cliffs: Prentice-Hall.
- Scheffler, H. W. (1976). 'The 'Meaning' of Kinship in American Culture: Another View', in *Meaning in Anthropology*, ed. K. H. Basso, and H. A. Selby. Albuquerque: University of New Mexico Press. pp. 57-91.
- Schneider, D. (1980). *American Kinship: A Cultural Account*. Englewood Cliffs: Prentice-Hall.
- Schneider, D. (1984). *A Critique of the Study of Kinship*. Ann Arbor: University of Michigan Press.
- Schusky, E. L. (1994). 'Kinship Terminology', in *The Encyclopedia of Language and Linguistics*, ed. R. E. Ashert, and J. M. Simpson, X. Oxford: Pergamon Press. pp. 1848-1852.
- Singarimbum, M. (1975). *Kinship, Descent, and Alliance among the Karo Batak*. Berkeley: University of California Press.
- Southwold, M. (1971). 'Meanings of Kinship', in *Rethinking Kinship and Marriage*, ed. R. Needham. London: Tavistock Publications. pp. 35-56.
- Strathern, A. (1972). *One Father, One Blood*. London: Tavistock Publications.
- Strathern, A. (1973). 'Kinship, Descent and Locality: Some New Guinea Examples', in *The Character of Kinship*, ed. J. Goody. Cambridge: Cambridge University Press.
- Strathern, M. (1992). 'Kinship Assisted', in *Reproducing the Future: Essays on Anthropology, Kinship and the New Reproductive Technologies*. Manchester: Manchester University Press. pp. 14-30.
- Strehlow, T. G., H. (1971). *Song of Central Australia*. Sydney: Angus and Robertson.
- Vatuk, S. (1969). 'A Structural Analysis of the Hindi Kinship Terminology'. *Contributions to Indian Sociology*, n.s., 3, 94-115.